



NHG-200C

2Gbps G.hn EoC Endpoint

The Netsys' NHG-200C is a 2 Giga LAN over 1.7 Gbps Coax endpoint, the idea of design by G.hn Wave-2 technology for higher than Gigabit-grade networking. The design can be used for home networking access applications. As endpoint networking gear it can be used to extend the house LAN over the existing TV cable, delivering Giga-grade connectivity for IP surveillance or secondary WiFi AP. Suitable for Point to Ethernet over Coax installation in point to point or point to multipoint networking access.

The coaxial interface includes two 75Ω F connectors for G.hn & TV ports with built in diplexer, so as to allow sharing the same coaxial outlet with a TV set.

Features

- Supports up to 16 endpoint connections
- Supports AES-128 encryption with individual key
- Extends LAN connectivity existing coaxial cable
- Supports Link quality indication
- Supports auto-speed up to 1.7Gbps
- Supports plug and play, no configuration required
- Attenuation up to -76db by RG-59/U coaxial cable
- Transmits CATV and Ethernet over coaxial cable
- Supports IGMP(IPv4) Snooping & MLD(IPv6) Snooping
- Built in surge protector for G.hn port

Specifications

Physical Interface	2 x RJ-45 with 10/100/1000Mbps 1 x F-type female connector for G.hn 1 x F-type female connector for STB/TV 1 x DC Jack
G.hn Modulation	OFDM
Working frequency	5MHz~200MHz
Max. Data Rate	1.7Gbps
TV Port Spectrum	250MHz ~ 1.2Ghz
Max. Attenuation	-76 db

Standards	IEEE802.3 / u/ab ITU-T G.9960 / 9961 ITU-T G.9962 / 9964
Indicators	LAN: Act/Link, Power; G.hn Quality: High/Middle/Low, Security
Power Consumption	3.9 watt
Certification	CE, FCC, RoHS Compliant
Dimensions	130 x 94.5 x 27 mm (5.12" x 3.72" x 1.06")
Temperature	0 ~50°C(Operating), -20 ~70°C(Storage)
Humidity	10 - 90% non-condensing

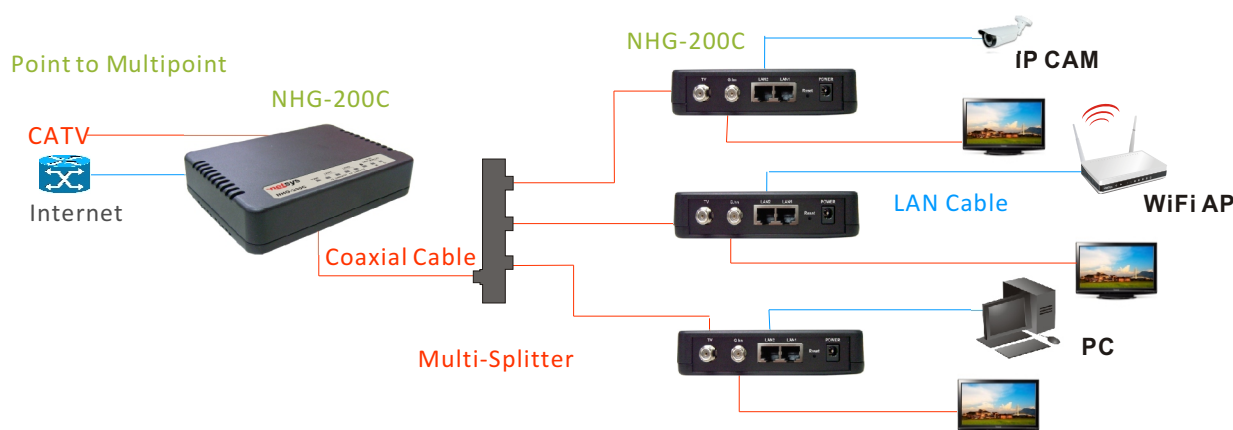

Application : Point to Multi-point networking