



**netsys**

*Networking your world*

**NV-450M / NV-450S**

**G.fast Master Modem +**

**G.fast / VDSL2 / V35b Slave Modem**

**USER'S MANUAL**

[Http://www.netsys.com.tw](http://www.netsys.com.tw)

## **Safety Warnings**

For user's safety, be sure to read and follow all warning notices and instructions before using the device.

- ◆ **DO NOT** open the device or unit. Opening or removing the cover may expose users to dangerous high voltage points or other risks. ONLY qualified service personnel can service the device. Please contact the user's vendor for further information.
- ◆ **Use ONLY** the dedicated power supply for user's device. Connect the power to the right plug type (AC support full range between 100Vac and 240Vac input. 12 Vdc / 2A or above).
- ◆ **Place** connecting cables carefully so that no one will step on them or stumble over them. **DO NOT** allow anything to rest on the power cord and do **NOT** locate the product where anyone can work on the power cord.
- ◆ **DO NOT** install nor use user's device during a thunderstorm. There may be a remote risk of electric shock from lightning.
- ◆ **DO NOT** expose user's device to dampness, dust, or corrosive liquids.
- ◆ **DO NOT** use this product near water, for example, in a wet basement or near a swimming pool.
- ◆ **Connect ONLY** suitable accessories to the device.
- ◆ **Make sure** to connect the cables to the correct ports.
- ◆ **DO NOT** obstruct the device ventilation slots, as insufficient air flow may harm user's device.
- ◆ **DO NOT** place items on the device.
- ◆ **DO NOT** use the device for outdoor applications directly, and make sure all the connections are indoors or have waterproof protection place.
- ◆ **Be careful** when unplugging power because it may produce sparks.
- ◆ **Keep** the device and all its parts and accessories out of the reach of children.
- ◆ **Clean** the device using soft and dry cloth rather than liquid or atomizers. Power off the equipment before cleaning it.
- ◆ This product is **recyclable**. Dispose of it properly.

**Attention:**

**Be sure to read this manual carefully before using this product. Especially Legal Disclaimer, Statement of Conditions and Safety Warnings.**

NV-450M/ NV-450S is a Managed Single Master/Slave LAN Extender that leverages the extraordinary bandwidth promise of G.fast technology (max. 1Gbps), the next generation in the delivery of new high-speed Internet applications in commercial environments. Quick, easy, economical to install and maintain, the NV-450M/NV-450S works over existing copper wire infrastructure. NV-450M is a Master (CO side) device. And NV-450S is a Slave (CPE side).

NV-450M/NV-450S will allow operators worldwide to compete with cable and satellite operators by offering services such as IP-TV 、 VOD 、 Video conference 、 Remote lecture 、 Telemedicine 、 Triple play Internet access and advanced applications including AI 、 IOT 、 Smart City 、 Smart traffic 、 5G Repeaters 、 Unmanned store 、 Security...etc , over a standard copper phone wire. NV-450M/ NV-450S is seen by many operators as an ideal accompaniment to a FTTdp rollout, where for instance fiber optic is supplied direct to an apartment block and from there copper cable is used to supply residents with high-speed G.fast.

**Caution:**

The NV-450M/ NV-450S is for **indoor** applications only. This product does not have waterproof protection, please do not use it in outdoor applications.

## **Table of Contents**

<b>CHAPTER 1. UNPACKING INFORMATION .....</b>	<b>6</b>
1.1 CHECK LIST .....	6
<b>CHAPTER 2. INSTALLING THE MODEM .....</b>	<b>7</b>
2.1 HARDWARE INSTALLATION .....	7
2.2 PRE-INSTALLATION REQUIREMENTS.....	7
2.3 GENERAL RULES.....	8
2.4 CONNECTING THE RJ-11 / RJ-45 PORTS .....	9
2.5 POINT TO POINT APPLICATION.....	10
<b>CHAPTER 3. HARDWARE DESCRIPTION .....</b>	<b>13</b>
3.1 FRONT PANEL.....	14
3.2 FRONT INDICATORS.....	15
3.3 REAR PANEL .....	17
3.4 BACK STICKER .....	19
<b>CHAPTER 4. CONFIGURE THE MODEM VIA WEB MANAGEMENT MENU.....</b>	<b>20</b>
<b>4.1 BASIC SETUP .....</b>	<b>21</b>
<b>4.1.1 Login Webpage.....</b>	<b>21</b>
<b>4.1.2 Display status .....</b>	<b>22</b>
<b>4.2 SELECT THE MENU BASIC.....</b>	<b>24</b>
<b>4.2.1 WAN Internet.....</b>	<b>25</b>
<b>4.2.2 G.fast DSL .....</b>	<b>26</b>

**NV-450M/S: G.fast Master Modem+ G.fast / VDSL2 / V35b Slave Modem USER'S MANUAL Ver. A.9**

4.2.2.1 Mode Setting .....	26
4.2.2.2 Status.....	29
This page provides various status and statistical information. ....	29
4.2.3 LAN .....	30
4.2.3.1 Configuration .....	30
4.2.3.2 Devices Connected .....	31
4.2.4 System.....	32
4.2.4.1 Administration .....	32
4.2.4.2 User Management .....	33
4.2.4.3 System Time .....	34
4.2.4.4 Diagnostics .....	35
4.2.5 Routing .....	37
4.3 SELECT THE ADVANCED MENU.....	38
4.3.1 Multicast .....	40
4.3.2 Dynamic DNS .....	41
4.3.3 UPnP .....	42
4.3.4 QoS .....	43
4.3.5 Tunneling.....	45
4.3.6 USB/SATA.....	45
4.3.7 Device Management.....	46
<b>APPENDIX A: CABLE REQUIREMENTS .....</b>	<b>48</b>
<b>APPENDIX B: PRODUCT SPECIFICATIONS.....</b>	<b>51</b>
<b>APPENDIX C: TROUBLESHOOTING .....</b>	<b>55</b>

**NV-450M/S: G.fast Master Modem+ G.fast / VDSL2 / V35b Slave Modem USER'S MANUAL Ver. A.9**

<b>APPENDIX D:</b> COMPLIANCE INFORMATION .....	61
WARRANTY.....	65
CHINESE SJ/T 11364-2024.....	66

## **Chapter 1. Unpacking Information**

### **1.1 Check List**

Thanks for choosing NV-450M/NV-450S. Before installing the modem, please verify the contents inside the package.

#### **Package Contents:**

	
1 x Modem	Accessory Kit : 1 x Ethernet Cable, 1 x Phone wire, 1 x DC12V/2A Power Adapter, 1 x Power cord.

#### **Notes:**

1. Please inform the user's dealer immediately for any missing or damaged parts. If possible, keep the carton including the original packing materials. Use them to repack the unit in case there is a need to return for repair.
2. Do not use sub-standard power supply. Before connecting the power supply to the device, be sure to check compliance with the specifications. The NV-450M/NV-450S uses a DC12V/2A or above Switching power supply.

## **Chapter 2. Installing the Modem**

### **2.1 Hardware Installation**

This chapter describes how to install the modem and establish the network connections. The NV-450S may be installed on any level surface (e.g. a table or shelf). However, please take note of the following minimum site requirements before users begin. **The NV-450M/NV-450S has 2 pre-installed rubber feet.**

### **2.2 Pre-installation Requirements**

Before the user starts the actual hardware installation, make sure users can provide the right operating environment, including power requirements, sufficient physical space, and proximity to other network devices that are to be connected.

Verify the following installation requirements:

- Power requirements: **DC 12 V / 2A or above**
- The modem should be located in a cool dry place, with at least **10cm/4in** of space at the front and back for ventilation.
- Place the modem away from direct sunlight, heat sources, or areas with a high amount of electromagnetic interference.
- Check if the network cables and connectors needed for installation are available.
- **Do not install phone lines strapped together with AC power lines, or telephone office line with voice signal.**
- **Avoid installing this device with radio amplifying stations nearby or transformer stations nearby.**

## **2.3 General Rules**

Before making any connections to the modem, please note the following rules:

- **Ethernet Port interface: RJ-45**

All network connections to the modem Ethernet port must be made using Category 5e UTP/STP or above for 1000 Mbps, Category 5 UTP or above for 100Mbps Category 3, 4 UTP or above for 10Mbps.

No more than 100 meters of cabling may be use between the MUX or HUB and an end node.

- **G.fast Port interface: RJ-11 & Terminal block combo**

All network connections to the RJ-11/ terminal block (sharing port) must use **24~26** gauge with single **twisted pair** phone wire.

We **do not recommend** the usage of the other gauge phone wire.

The RJ-11 is a 6P4C connector, two of which are wired. The modem uses two pins at the center. The pin out assignment for these connectors is shown below.

Please note that the line port is without polarity, therefore users can reverse the two wires of the phone cable when installed.

RJ-11 Pin out Assignments.

Pin#	MNEMONIC	FUNCTION
1	NC	Unused
2	2a	Pass through
<b>3</b>	<b>1a</b>	<b>G.fast / xDSL</b>
<b>4</b>	<b>1b</b>	<b>G.fast / xDSL</b>
5	2b	Pass through
6	NC	Unused

### **2.4 Connecting the RJ-11 / RJ-45 Ports**

There are two types of line: 1 Terminal Block & 1 RJ-11 connector. It is used to connect with NV-450M Master side over a single pair phone wire to NV-450S Slave side (point to point application). (Figure 2.1)

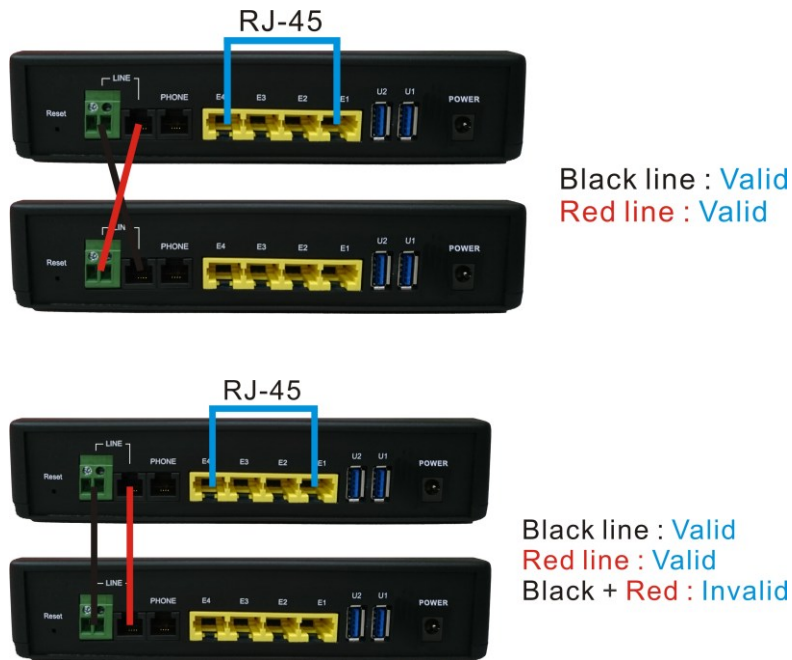

**Figure 2.1 NV-450M/NV-450S line ports straight connection**

- ◆ When inserting a RJ-11 plug, make sure the tab on the plug clicks into position to ensure that it is properly seated.
- ◆ **Do not** plug an RJ-11 phone jack connector into the Ethernet port (RJ-45 port). This may damage the modem. Instead, use only twisted-pair cables with RJ-45 connectors that conform to Ethernet standard.

**Notes:**

1. Be sure each twisted-pair cable (RJ-45 Ethernet cable) does not exceed 100 meters (333 feet).
2. We advise using Category 5~7 UTP/STP cables for making Ethernet connections to avoid any confusion or inconvenience in the future when users attach high bandwidth devices.
3. Use 24 ~ 26 gauge twisted pair phone wiring, we do not recommend the usage of the other gauge phone wire.
4. Be sure phone wire has been installed before the NV-450S/ NV-450M boot.
5. Do not connect Line port with RJ-11 and Terminal block to two Master / Slave device

## **2.5 Point to Point Application**

First a quick overview on a complete setup of LAN extender Master/Slave LAN extender.

NV-450M/NV-450S is a LAN extender that leverages the extraordinary bandwidth promise of G.fast technology (max. 1Gbps)  
([Figure 2.2](#))

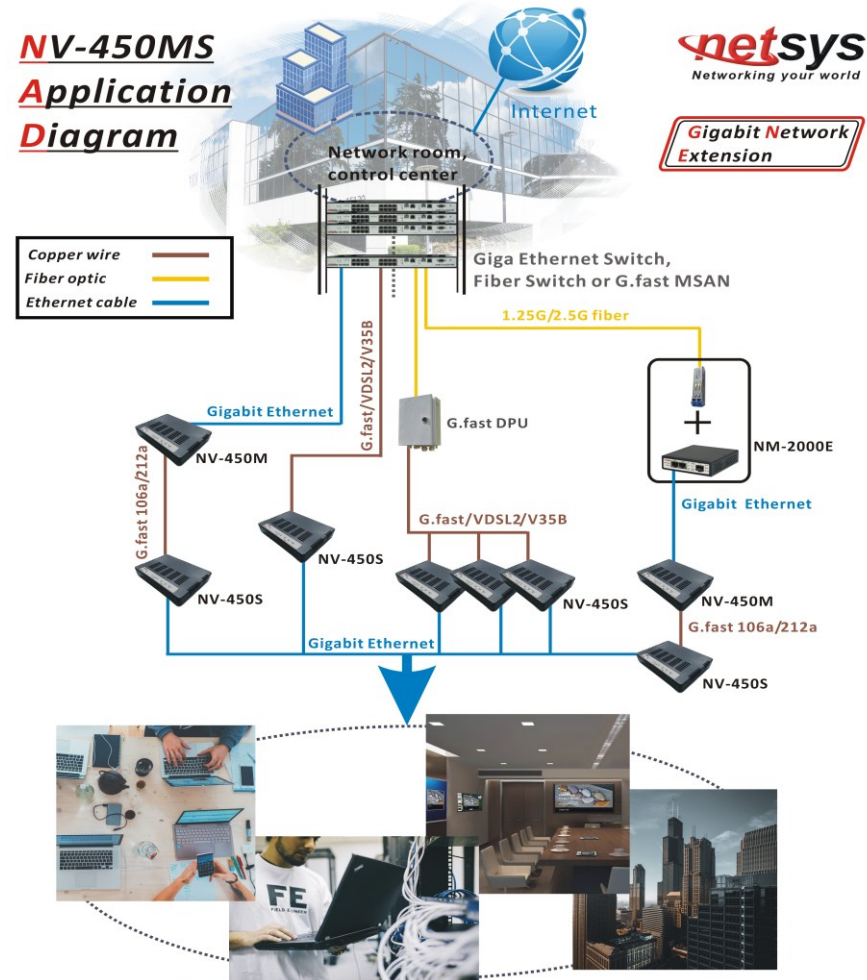

System management, SOHO or Enterprise network connection, MTU or Hotel network service provision, Video conference, Digital signage etc..

**Figure 2.2 NV-450M/NV-450S Point to Point application.**

◆ **2.5.1 Connect the NV-450M(Master) and the NV-450S(Slave) to the Line**

The objective for LAN extender is to pass high speed data over a twisted pair cable. In the setup, connect NV-450M(Master) to NV-450S (Slave) through phone wire (24~26 AWG) or line simulator or any other hardware representation of a cable network, with or without noise injection and crosstalk simulations.

◆ **2.5.2 Connect the NV-450M(Master) and the NV-450S(Slave) to LAN Devices**

In the setup, usually an Ethernet tester serves as a representation of the LAN side as well as a representation of the WAN(Line) side.

◆ **2.5.3 Run Demos and Tests**

The Ethernet tester may send data downstream as well as upstream. It also receives the data in order to check the integrity of the data transmission. Different data rates can be tested under different line conditions.

## **Chapter 3. Hardware Description**

This section describes the important parts of the NV-450M/S. It features the front panel and rear panel.



## NV-450 Physical appearance

### **3.1 Front Panel**

The figure shows the front panel. (Figure 3.1)

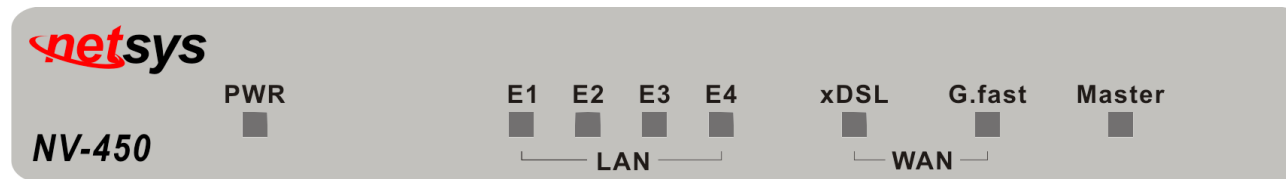

**Figure 3.1 Front Panel (NV-450M/NV-450S)**

#### **Note:**

- 1. Identifying NV-450M(Master) or NV-450S Model (Slave) is by Master LED, when this LED On(steady) indicates firmware Model as MV-450M, and LED Off indicates firmware Model as NV-450S.**
- 2. If want to change NV-450M to NV-450S Model, just update firmware to NV-450S. The reverse is also do the same step. Fireware update menu please refer to administration webpage on page 30.**
- 3. Please click default reset menu on administration webpage after model firmware updating.**

### **3.2 Front Indicators**

The Modem has **Seven** LED indicators. The following Table shows the description. (Table 3-1)

**Table 3-1** LED Indicators Description and Operation

LED	Color	Status	Descriptions
PWR (Power LED)	Green	On (Steady)	Lights to indicate that modem had power good
		Off	The device is not ready or has malfunctioned.
LED	Color	Status	Descriptions
E1 ~ E4 (Ethernet LED)	Green	On (Steady)	The device has a good Ethernet connection.
		Blinking	The device is sending or receiving data.
		Off	The LAN is not connected or has malfunctioned.
G.fast (G.fast LED)	Green	On (Steady)	The G.fast connection is up.
		Fast Blinking	The Master device has detected a Slave device and ready to connect.
		Off	The Internet or network connection is down.

**NV-450M/S: G.fast Master Modem+ G.fast / VDSL2 / V35b Slave Modem USER'S MANUAL Ver. A.9**

xDSL (xDSL LED for NV-450S only)	Green	On (Steady)	The xDSL connection is up.
		Fast Blinking	The Master device has detected a Slave device and ready to connect.
		Off	The Internet or network connection is down.
Master	Green	On (Steady)	Device firmware on NV-450M (Master mode).
		Off	Device firmware on NV-450S (Slave mode).

### **3.3 Rear Panel**

The following figure shows the rear panel. (Figure 3.2)



**Figure 3.3 Rear Panel**

And the table shows the description. (Table 3-2)

**Table 3-2** Description of the modem rear connectors

Type	Connector	Description
Reset	Tact Switch Button	The reset buttons allow users to reboot the LAN NV-450M/ NV-450S or load the default settings. <b>Press and hold for 1-5 seconds: Reboot the NV-450S.</b> <b>Press over 5 seconds: Load the default settings</b>
Power	DC Jack	External switching Power Adapter: Input: AC 85~240Volts/50~60Hz. Output: DC 12V/2A.
Line	RJ-11	For connecting to a Master/Slave device.

**NV-450M/S: G.fast Master Modem+ G.fast / VDSL2 / V35b Slave Modem USER'S MANUAL Ver. A.9**

Type	Connector	Description
phone	RJ-11	For connecting to the POTS equipment or ISDN.
Ethernet (E1-E4)	RJ-45	For connecting to an Ethernet equipped device.
USB3.0 (U1-U2)	USB Type A	For connecting to the USB dongle.

**Before user installed power and device, please read and follow these essentials:**

- ◆ Use separate paths to route wiring for power and devices. If power wiring and device wiring paths must cross, make sure the wires are perpendicular at the intersection point.

**Note:**

Do not run signal or communications wiring and power wiring through the same wire conduit. To avoid interference, wires with different signal characteristics should be routed separately.

- ◆ Users can use the type of signal transmitted through a wire to determine which wires should be kept separate. The rule of thumb is that wiring sharing similar electrical characteristics can be bundled together.
- ◆ Users should separate input wiring from output wiring.
- ◆ We recommend that users mark all equipment into the wiring system.

### **3.4 Back sticker**

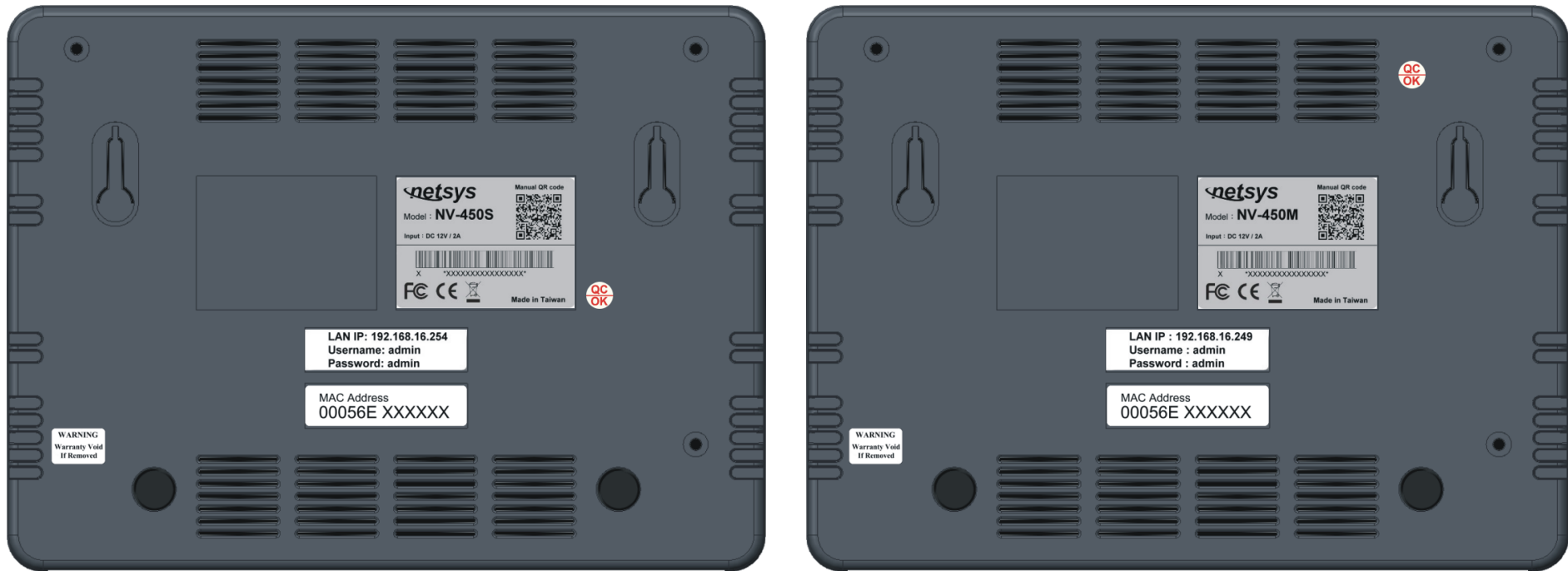

**Note : 1.Default factory model shown as back sticker including default model name, S/N 、FCC CE Mark, Input DC voltage information, User's manual download QR code, made of origin, default LAN IP and web management login information.**

## **Chapter 4. Configure the modem via Web management menu.**

The NV-450M/ NV-450S provides a built-in HTML based management interface that allows configuration of the NV-450S via Internet Browser. Best viewed using Chrome or Firefox browsers.

In order to use the web browser to configure the device, users may need to allow:

- Web browsers pop-up windows from user's devices. Web pop-up blocking is enabled by default in windows XP SP2 or above.
- Java Scripts. (Enabled by default)
- Java permissions. (Enabled by default)

Launch user's web browser and input the default IP address **192.168.16.249** (NV-450M) / **192.168.16.254** (NV-450S) on the Web page.

The following section user can find default username and password.

## **4.1 BASIC Setup**

### **4.1.1 Login Webpage**

The default username and password are “admin”.

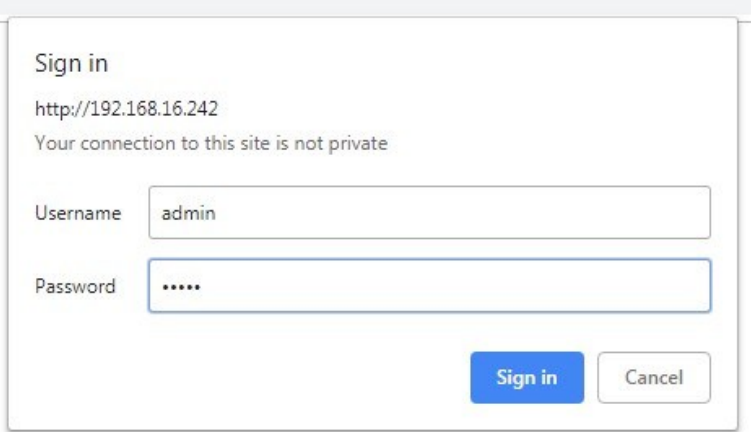

Sign in  
http://192.168.16.242  
Your connection to this site is not private

Username

Password

**Figure 4.1.1 Login Webpage**

## 4.1.2 Display status

When the device is running, the status page will display the device information (Internet Status, Software Version and DSL Line Status etc.), as shown in [Figure 4.1.2](#).

NV-450M

The screenshot displays the NetSys web interface for an NV-450M Managed G.fast Master Modem. The interface includes a navigation menu on the left with options for Basic, Advanced, G.fast, LAN, System, and Routing. The main content area is divided into three sections: Device Status, System Info, and DSL Line Status.

**Device Status**

- Internet Status: Up
- Internet Status: Status ↑
- PTM WAN, Proto: Bridged

**System Info**

- Software Version: B.4.3

**DSL Line Status**

- Upstream Data Rate (kbps): 665431
- Downstream Data Rate (kbps): 320845

**Figure 4.1.2 Device Info**

NV-450S

The screenshot displays the web interface for the NV-450S modem. On the left is a navigation menu with 'Basic' and 'Advanced' sections. The 'Advanced' section is active, showing options for WAN Internet, DSL, LAN, System, and Routing. The main content area is divided into three panels: 'Device Status', 'System Info', and 'DSL Line Status'. The 'Device Status' panel shows 'Internet Status : Down' and 'WAN IP :'. Below this is a table for 'Internet' settings. The 'System Info' panel shows 'Software Version: B.4.6'. The 'DSL Line Status' panel shows 'Upstream Data Rate (kbps): 0' and 'Downstream Data Rate (kbps): 0'.

Internet	
Status ↓	PTM WAN, Proto: Bridged
Internet Address	
Default Gateway	
Subnet Mask	
Primary DNS	
Secondary DNS	

**Figure 4.1.2 Device Info**

## **4.2 Select the Menu Basic**

There is an easy Setup for end users at the setup of NV-450M with **G.fast, LAN, System, Routing** and NV-450S with **WAN Internet, DSL, LAN, System, Routing** for more detail configurations.

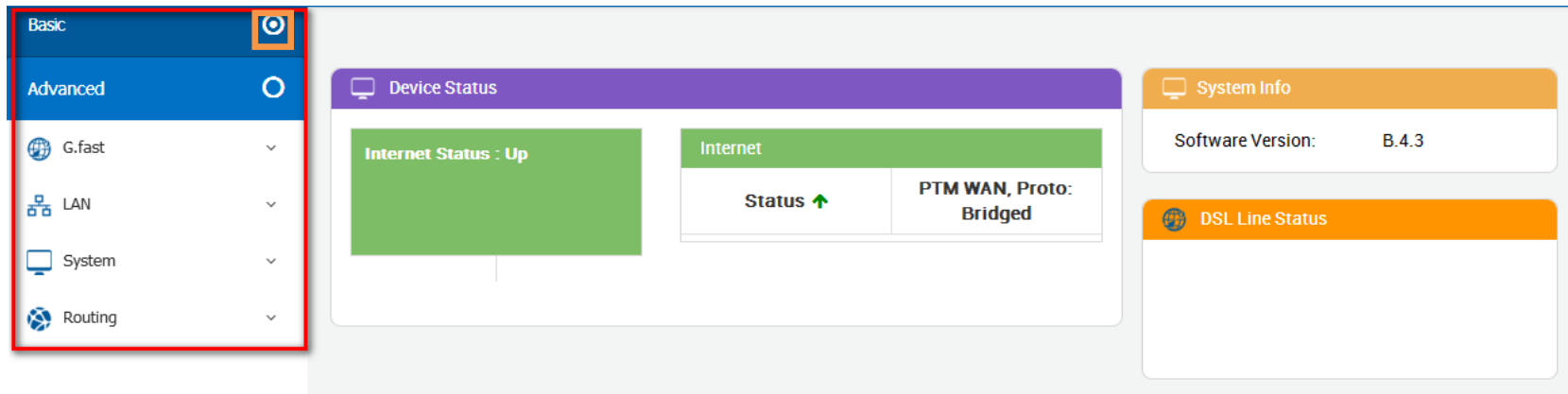

**Figure 4.2 Select the Menu Basic**

## 4.2.1 WAN Internet

This page allows users to view and configure various Internet connections.

The screenshot displays the WAN Internet configuration interface. On the left is a navigation sidebar with categories: Basic, Advanced, WAN Internet, DSL, LAN, System, and Routing. The main content area is titled 'Internet Connections' and includes a sub-header 'Internet Status'. Below this, there are tabs for 'IPv4' and 'IPv6'. A table lists two WAN connections:

Description	IP Address	Interface	Status	Default Gateway	Actions
PTM WAN, Proto: Bridged		ptm0_wan3	↓	✓	Connect
LTE WAN, Proto: DHCP		wwan0	↓	✗	Connect

**Figure 4.2.1 WAN Internet information**

## 4.2.2 G.fast DSL

### 4.2.2.1 Mode Setting

DSL (Digital Subscriber Line) offers WAN DSL Connectivity on various DSL Modes. Provides configuration for xDSL/G.fast modes, and upstream & downstream attributes.

#### **NV-450M:**

NV-450M provides G.fast mode configuration for customized unitization, which users can simply select profile 106a/212a & mode symmetry/asymmetry from G.fast mode setting.

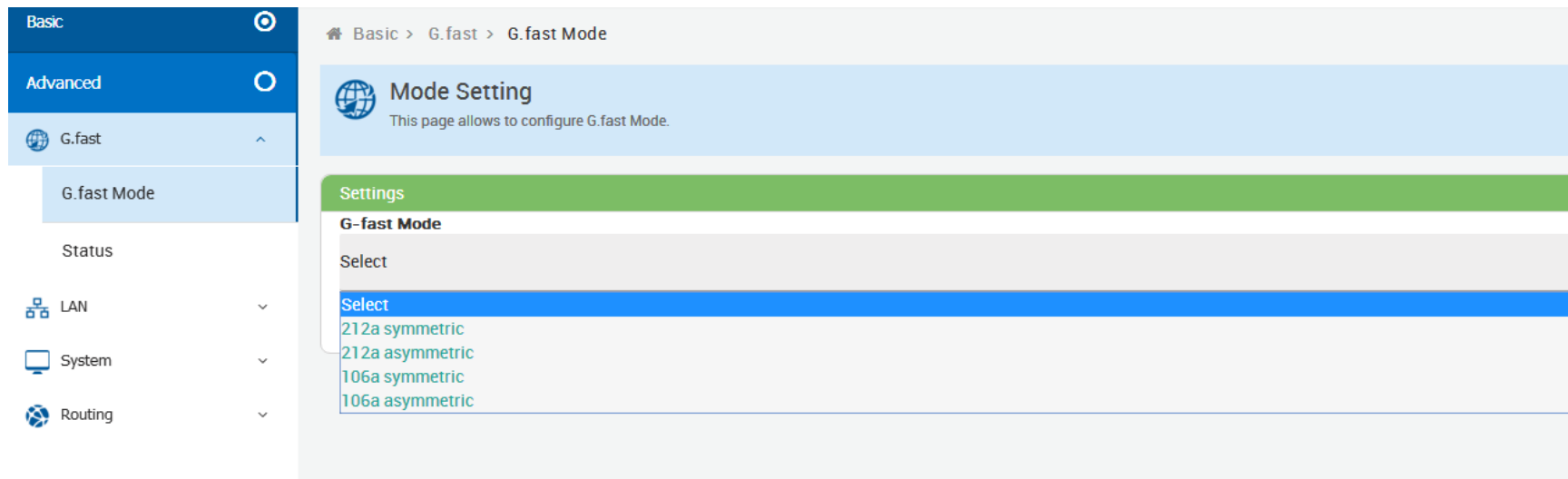

**Figure 4.2.2.1 G.fast Mode Setting**

## **NV-450S:**

The NV-450S is defaulted to connect and auto follow the NV-450M Master side. Therefore, do not change the mode settings on the NV-450S when connecting to a Netsys NV-450M. The default settings are configured to connect and pass data at the fastest available speeds based on the current line conditions.

When connecting the Netsys NV-450S to a modem or DSLAM from another manufacturer, the following mode settings are available:

**\* VDSL US/DS Rate Adaptation:** Using this technique the line is more tolerant of errors caused by noise and signal loss. As the parameters are adjusted, the bandwidth may be markedly decreased if there is a large amount of line noise or signal degradation.

**\* VDSL US/DS Retransmission:** This technique is to resend damaged or lost packets. Please select it to activate the function.

**\* Vectoring:** Vectoring is a transmission method that employs the coordination of line signals for reduction of crosstalk levels and improvement of performance. To configure the vectoring function, please select it from the drop-down Vectoring menu.

**\* DSL PHY-TC:** To configure DSL mode, please select from DSL PHY-TC drop-down menu.

The default settings for the NV-450S are as follows:

The screenshot shows a web interface for configuring DSL settings. On the left is a navigation menu with 'Basic' and 'Advanced' sections. Under 'Advanced', there are links for 'WAN Internet', 'DSL', 'LAN', 'System', and 'Routing'. The 'DSL' link is expanded to show 'Mode Setting', 'Status', and 'VDSL2'. The main content area is titled 'Mode Setting' and includes a subtitle: 'DSL(Digital Subscriber Line) offers WAN DSL Connectivity on various DSL Modes. Provides configuration for xDSL modes, various annex modes and upstream and downstream attributes.' Below this is a 'Settings' section with a green header. The 'DSL' toggle is turned 'ON'. The 'DSL PHY - TC' dropdown is set to 'Auto'. The 'VDSL DS Retransmission' and 'VDSL DS Rate Adaptation' options are both checked with green checkmarks. The 'Modes' section shows 'VDSL2' selected with a green checkmark. On the right side, 'US Retransmission' and 'VDSL US Rate Adaptation' are also checked with green checkmarks. The 'Vectoring' dropdown is set to 'Auto'.

**Figure 4.2.2.1 Mode Setting**

### 4.2.2.2 Status

This page provides various status and statistical information.

The screenshot shows the 'Status and Statistics' page in a modem's web interface. The left sidebar contains navigation options: Basic (selected), Advanced, WAN Internet, DSL (expanded), Mode Setting, Status (selected), LAN, System, and Routing. The main content area shows the breadcrumb 'Basic > DSL > Status' and the title 'Status and Statistics' with a subtitle 'Provides the various status and statistics information'. Below this, there are two main sections: 'Line Information' and 'Channel Information'. The 'Line Information' section shows 'Modem Status' as 'Down' and 'Power Management Mode' as 'L3'. The 'Channel Information' section shows 'Mode Selected' as 'G.993.2\_Annex\_K\_PTM', 'Upstream Data Rate (Kbps)' as '0', and 'Downstream Data Rate (Kbps)' as '0'.

Line Information	Channel Information
<b>Modem Status</b> Down	<b>Mode Selected</b> G.993.2_Annex_K_PTM
<b>Power Management Mode</b> L3	<b>Upstream Data Rate (Kbps)</b> 0
	<b>Downstream Data Rate (Kbps)</b> 0

**Figure 4.2.2.2 Status**

## 4.2.3 LAN

### 4.2.3.1 Configuration

Configuration support to provide IP addresses to devices connected on the LAN side of the CPE. Applicable for all wired and wireless devices that request dynamic IP address.

The screenshot displays the 'Local Network Settings' configuration page for IPv4. The left sidebar contains navigation options: Basic, Advanced, WAN Internet, DSL, LAN (selected), Configuration (selected), Devices Connected, System, and Routing. The main content area shows the breadcrumb 'Basic > LAN > Configuration' and the title 'Local Network Settings' with a description: 'Configuration support to provide IP address to devices connected on the LAN side of the CPE. Applicable for all wired and wireless devices that requests for dynamic IP address'. Below this, there are tabs for 'IPv4' (active) and 'IPv6'. The 'IPv4 Configuration' section includes fields for 'Device IP Address' (192.168.16.242), 'Subnet Mask' (255.255.255.0), and 'DHCP Mode' (Disable). 'Apply' and 'Reset' buttons are at the bottom. The 'IP Address Reservation' section has a table with columns for 'MAC Address' and 'IP Address', and an '+ Add' button.

**Figure 4.2.3.1 Configuration**

### 4.2.3.2 Devices Connected

List of Clients Connected on the LAN Side of the device.

The screenshot displays the 'Devices Connected' page within a modem's configuration interface. The left sidebar contains navigation options: Basic, Advanced, WAN Internet, DSL, LAN (selected), Configuration, Devices Connected (highlighted), System, and Routing. The main content area shows the breadcrumb 'Basic > LAN > Devices Connected' and a title 'Devices Connected' with a subtitle 'List of Clients Connected on the LAN Side of the device'. Below this is a table with three columns: MAC Address, Host Name, and IP Address. The table lists five connected devices. A 'Refresh' button is positioned at the bottom right of the interface.

MAC Address	Host Name	IP Address
88:d7:f6:54:fc:f6	Unknown	192.168.16.15
10:c3:7b:46:06:8f	Unknown	192.168.16.3
ac:22:0b:8c:13:73	Unknown	192.168.16.26
00:05:6e:02:07:02	Unknown	fe80::1
30:e1:71:6a:6d:b3	Unknown	fc00::96d

**Figure 4.2.3.2 Devices Connected**

## **4.2.4 System**

### **4.2.4.1 Administration**

This page allows users to take configuration backup, restore to previous configuration or to factory settings, upgrade firmware and reboot device.

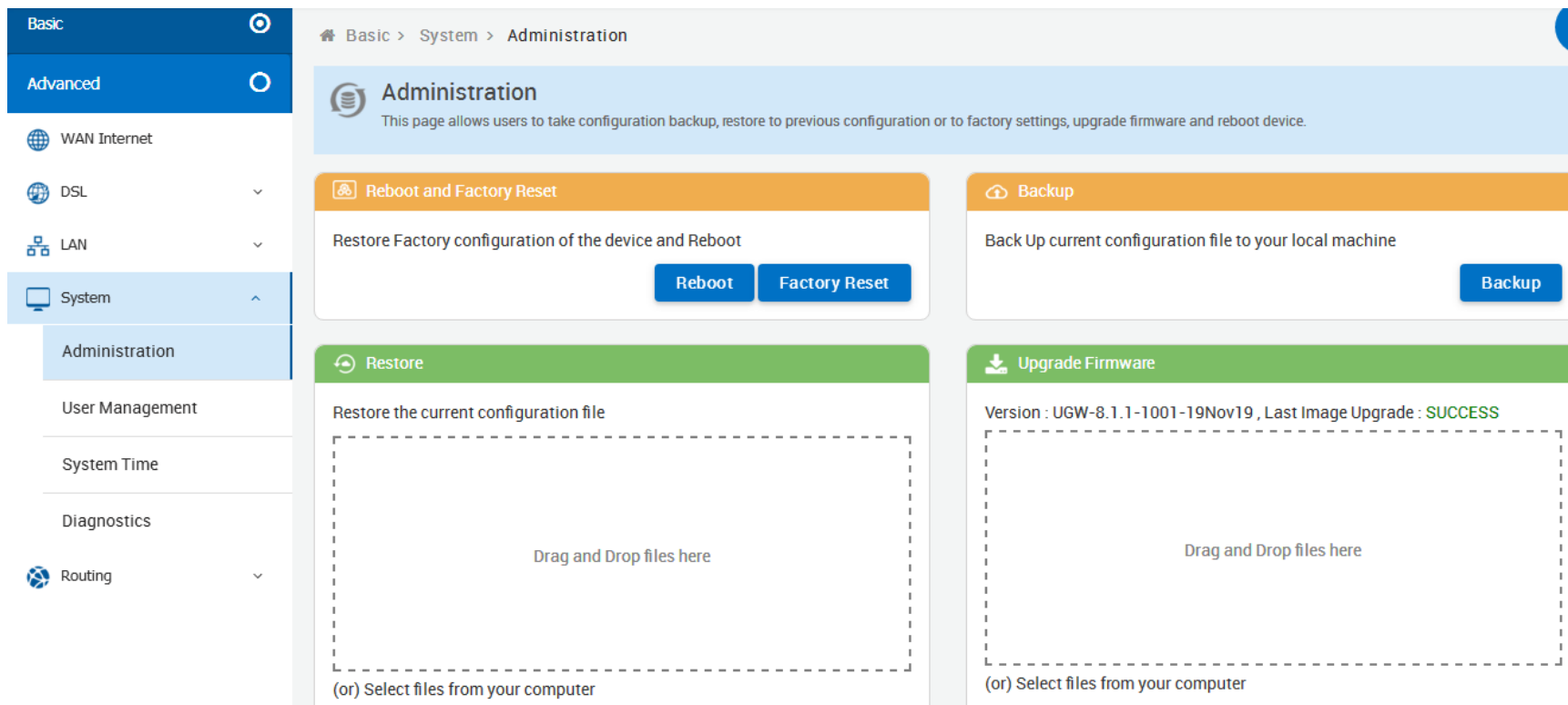

**Figure 4.2.4.1 Administration**

#### **4.2.4.2 User Management**

Configure new users with add delete and modify options.

Basic > System > User Management

### User Management

Configure new users with add delete and modify options

Enable	Username	Role	Web	System, SSH & Telnet	Actions
✓	root	super_admin	✗	✓	
✓	admin	super_admin	✓	✓	

[Add](#)

**Figure 4.2.4.2 User Management**

### 4.2.4.3 System Time

Configuration to enable the device to synchronize the system time with the time servers.

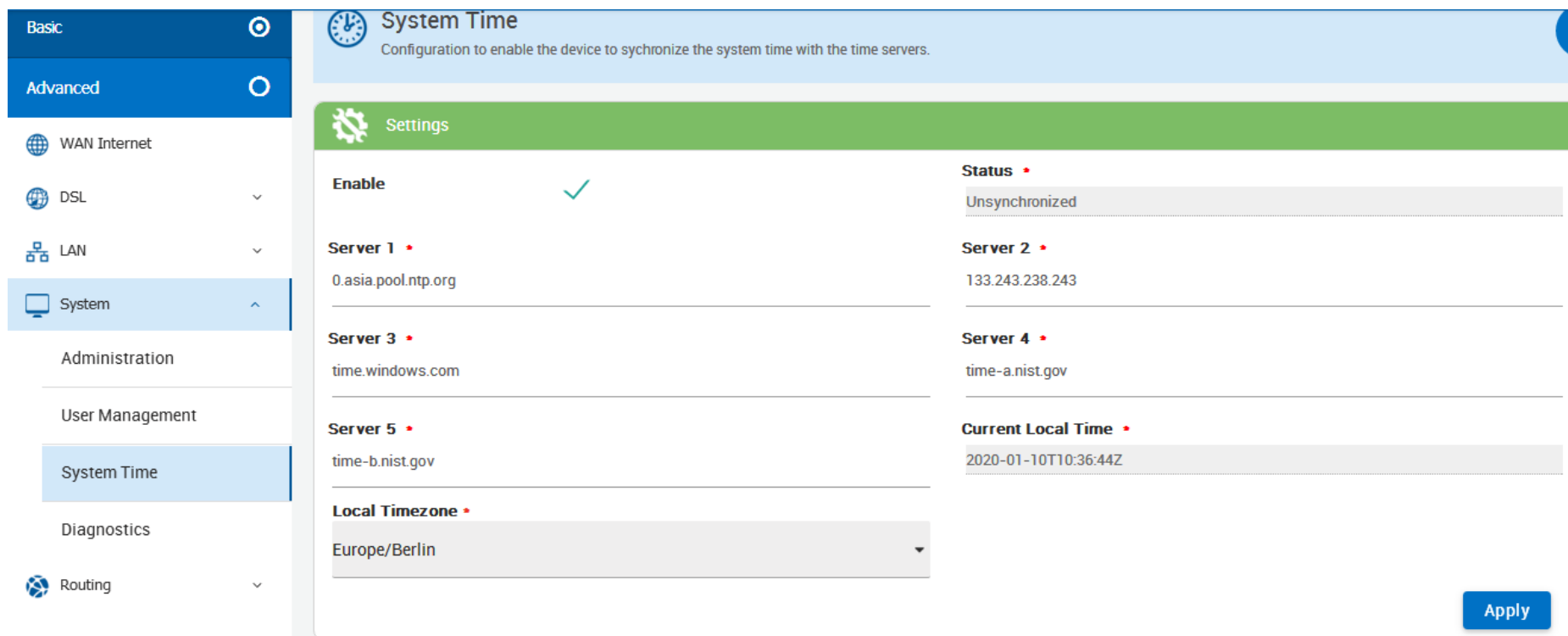

**Figure 4.2.4.3 System Time**

#### **4.2.4.4 Diagnostics**

Allows to perform diagnosis on various sub-systems of this device.

**Basic**

**Advanced**

WAN Internet

DSL

LAN

**System**

Administration

User Management

System Time

**Diagnostics**

Routing

**Diagnostics**

**Restart**

**LAN**

**LAN Connectivity**

- ✗ ETHERNET eth0\_1: LINK DOWN
- ✓ ETHERNET eth0\_2: LINK UP , Speed : 100 kbps , Mode : Full
- ✗ ETHERNET eth0\_3: LINK DOWN
- ✗ ETHERNET eth0\_4: LINK DOWN

**Ping Test**

Enter IP/Host Address Here

**Ping Test**

**Traceroute Test**

Enter URL Here

**Trace Route**

**Figure 4.2.4.4 Diagnostics**

## 4.2.5 Routing

Web Page to Add/Delete Static Route in the System

Basic > Routing > Static Routing

### Static Routing Configurations

Web Page to Add/Delete Static Route in the System

Destination IP Address	Destination Subnetmask	Gateway IP Address	Actions
------------------------	------------------------	--------------------	---------

Add

Enable	Destination IP Prefix	Next Hop	Actions
✓			

Add

**Figure 4.2.5 Static Routing**

## **4.3 Select the Advanced Menu**

Select “Advanced”. The menu below will be used frequently. NV-450M includes the sub-menus of **UPnP**、**USB/SATA**、**Device Management**. NV-450S includes the sub-menus of **Multicast**、**Dynamic DNS**、**UPnP**、**QoS**、**Tunneling**、**USB/SATA**、**Device Management**. A screen is displayed as shown in [Figure 4.3](#)

NV-450M

The screenshot displays the web interface for the NV-450M modem. On the left, a navigation menu is visible with the following items: 'Basic' (selected), 'Advanced' (selected), 'UPnP', 'USB/SATA', and 'Device Management'. The main content area is titled 'Device Status' and contains three panels: 'Internet Status : Up' (green), 'Internet' (green) with a sub-table showing 'Status ↑' and 'PTM WAN, Proto: Bridged', and 'DSL Line Status' (red) with sub-tables for 'Upstream Data Rate (kbps) 662783' and 'Downstream Data Rate (kbps) 343651'. To the right of the main content, there is a 'System Info' panel showing 'Software Version: B.4.3'.

Internet	
Status ↑	PTM WAN, Proto: Bridged

DSL Line Status	
Upstream Data Rate (kbps)	662783
Downstream Data Rate (kbps)	343651

NV-450S

The screenshot displays the advanced configuration interface of the NV-450S modem. On the left, a navigation menu includes 'Basic' and 'Advanced' (selected), with sub-items: Multicast, Dynamic DNS, UPnP, QoS, Tunneling, USB, and Device Management. The main content area is divided into three panels:

- Device Status:** Shows 'Internet Status : Down' and 'WAN IP :'. Below this is a table for 'Internet' settings.
- System Info:** Shows 'Software Version: B.4.6'.
- DSL Line Status:** Shows 'Upstream Data Rate (kbps): 0' and 'Downstream Data Rate (kbps): 0'.

Status ↓	PTM WAN, Proto: Bridged
Internet Address	
Default Gateway	
Subnet Mask	
Primary DNS	
Secondary DNS	

**Figure 4.3 Advanced**

### 4.3.1 Multicast

This page allows you to configure the Multicast services.

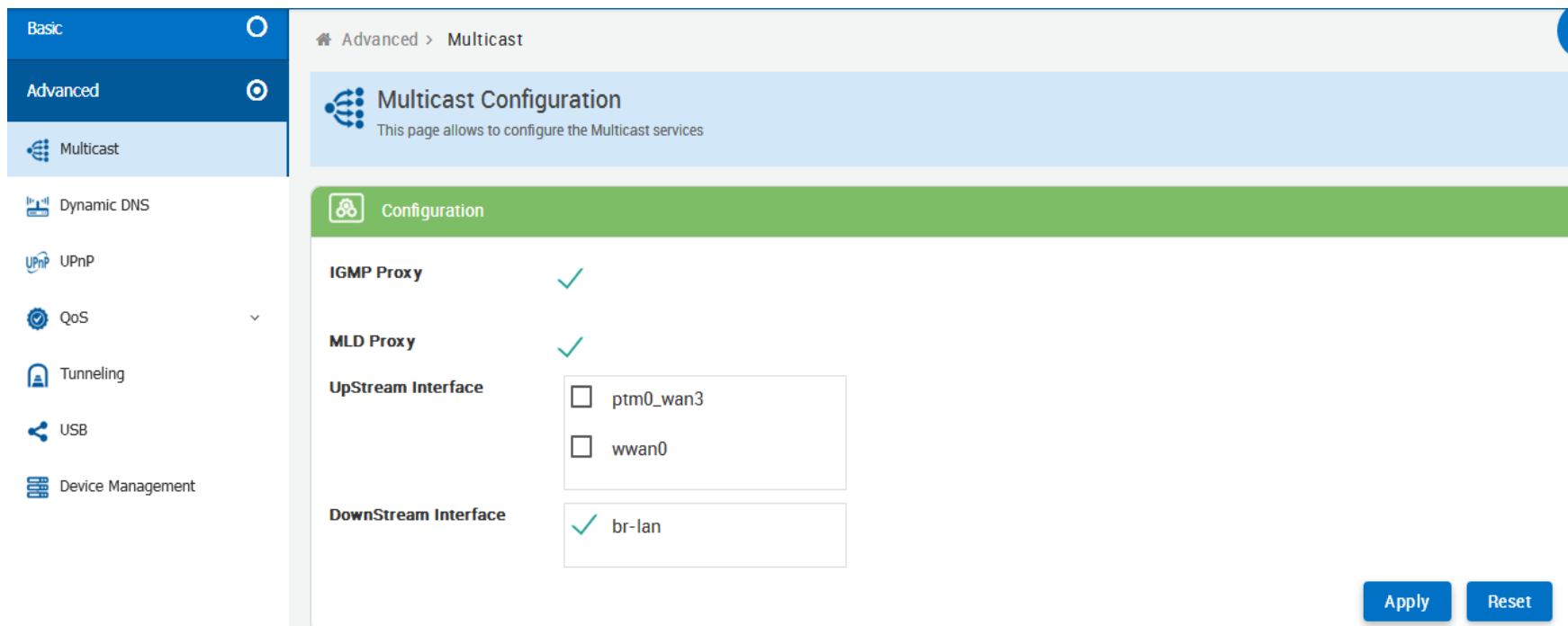

**Figure 4.3.1 Multicast**

### 4.3.2 Dynamic DNS

Dynamic DNS allows the user to update WAN IP address with one or many dynamic DNS services. So, anyone can access services on computer using DNS-like address.

Advanced > Dynamic DNS

**Dynamic DNS**  
Dynamic DNS allows the user to update wan IP address with one or many dynamic DNS services. So anyone can access services on computer using DNS-like address.

**Client Settings**

Enable	Interface	Server	Actions

[Add](#)

**Supported Servers**

Enable	Name	ServiceName	ServerAddress	Actions
✓	dhs	dhs	dyn.dhs.org	
✓	dyndns	dyndns	dyndns.org	
✓	dyns	dyns	dyns.cx	

[Add](#)

**Figure 4.3.2 Dynamic DNS**

### 4.3.3 UPnP

This page provides UPnP devices & service.

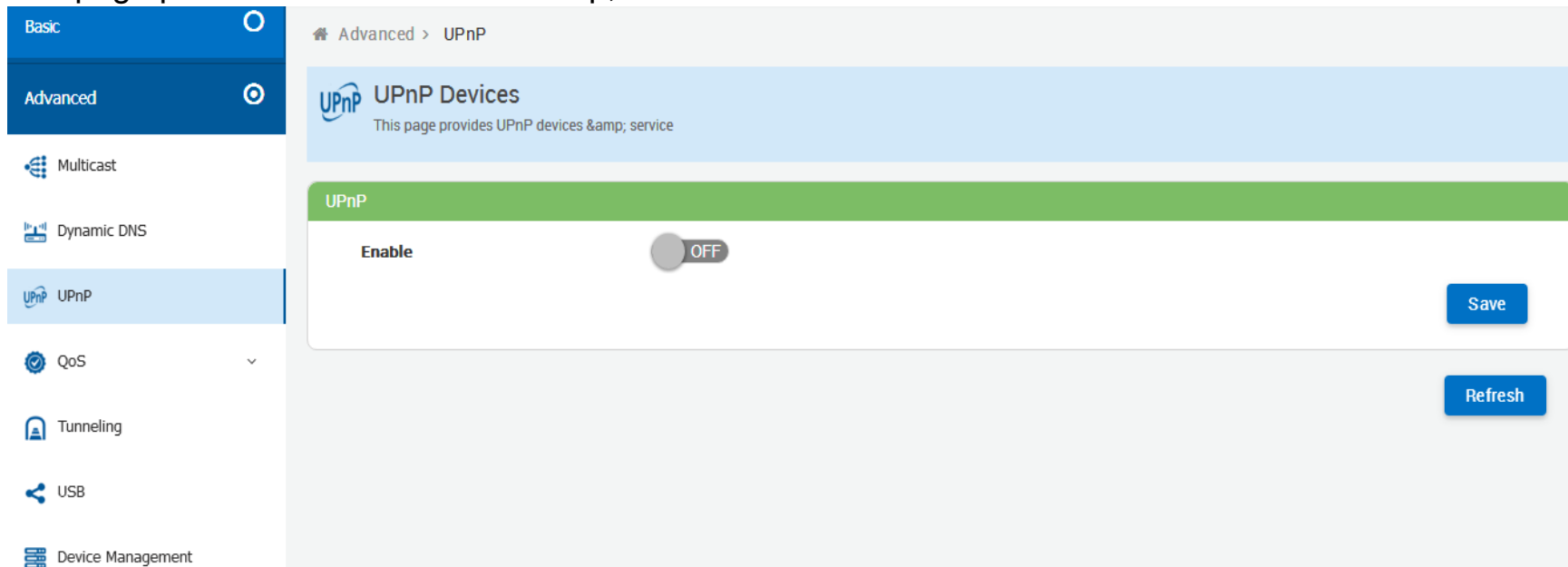

**Figure 4.3.3 UPnP**

### 4.3.4 QoS

Quality of Service (QoS) settings enables users to manage and optimize the performance of the applications. It shapes the network traffic and prioritizes the devices and services by controlling the bandwidth allocation.

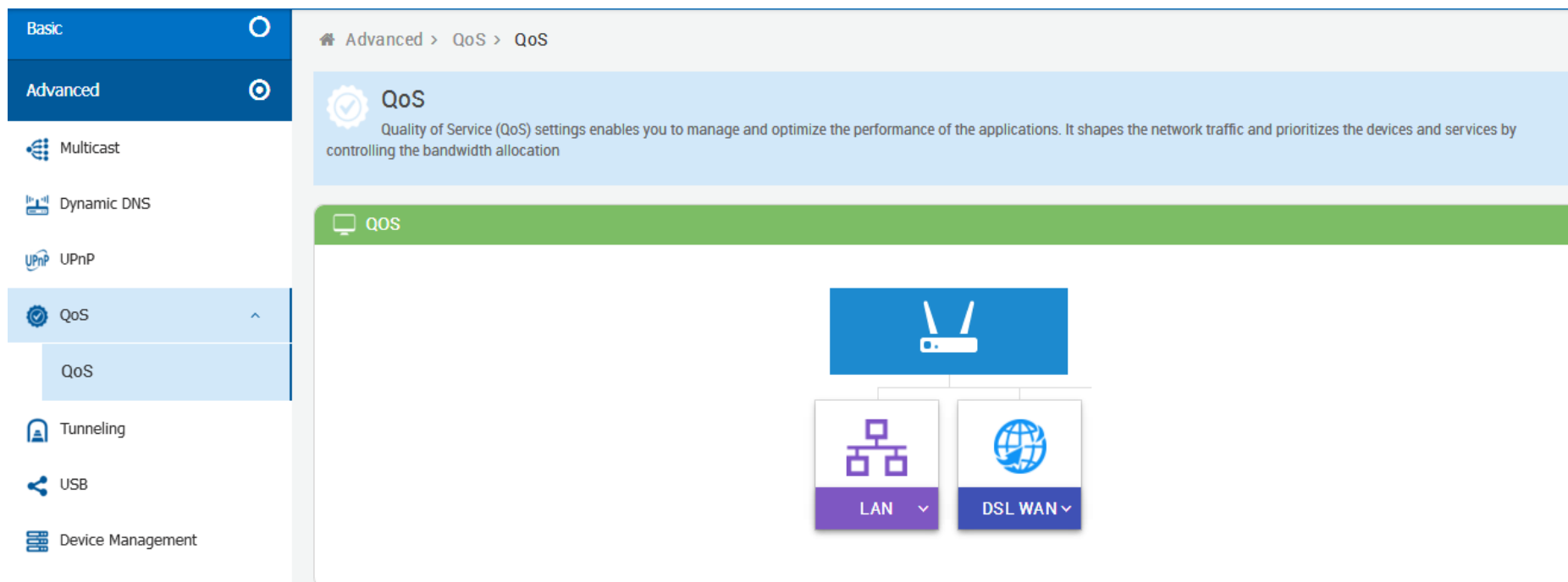

The screenshot displays two sections of a network configuration interface. The top section, titled "Queue", has a red header and contains two entries: "ptmwan\_def\_queue" and "ptmwan\_mgmt\_q". Each entry is preceded by a green checkmark and followed by a blue "More" button with a downward arrow. The bottom section, titled "QoS Configuration", has an orange header and contains a table with the following data:

Traffic Class	Default DSCP Mark	Eth Priority Mark	Enable	Actions
0	-1	-1	✓	

**Figure 4.3.4 QoS**

### 4.3.5 Tunneling

6rd is a mechanism to facilitate IPv6 rapid deployment across IPv4 infrastructures of Internet service providers (ISPs). DS Lite is a mechanism to facilitate IPv4 deployment across IPv6 infrastructure.

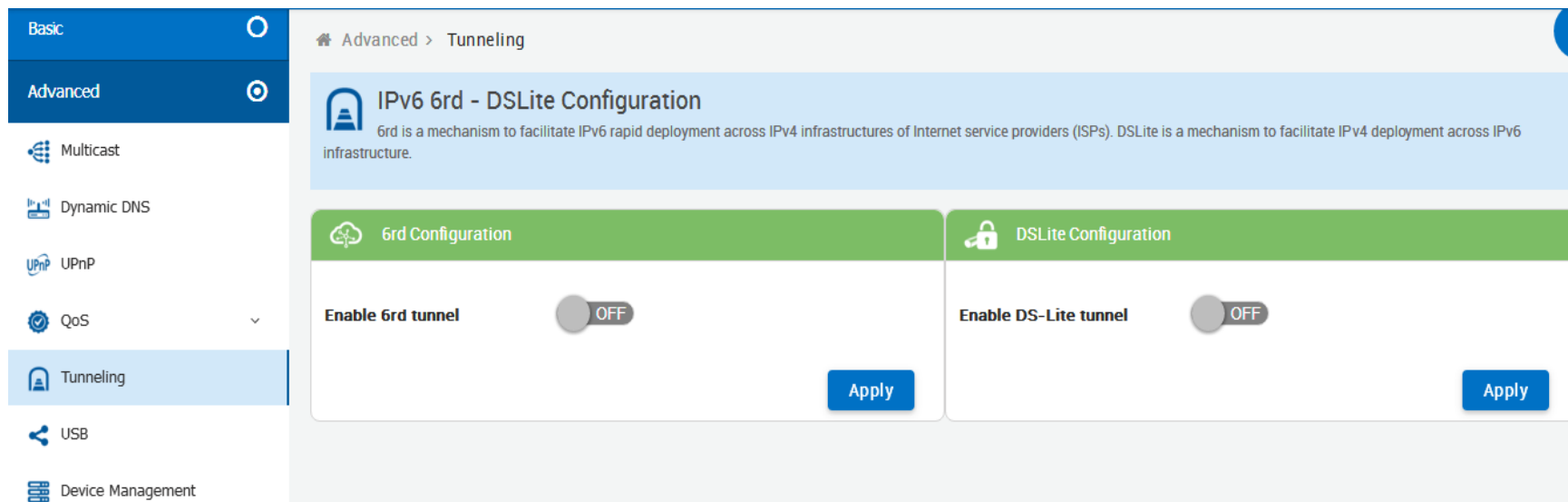

**Figure 4.3.5 Tunneling**

### 4.3.6 USB/SATA

Always ensure that user's click on the Safe Remove button to safely remove respective USB/SATA storage devices.

The screenshot displays a web-based management interface for USB/SATA devices. On the left is a navigation sidebar with options: Basic, Advanced, Multicast, Dynamic DNS, UPnP, QoS, Tunneling, USB (selected), and Device Management. The main content area is titled 'Advanced > USB'. It features a blue header with a USB icon and the text 'USB' and 'Always ensure that you click on the Safe Remove button to safely remove respective USB storage devices.' Below this is a green section for 'Connected USB Devices' with a table with columns: Type, USB Version, Manufacturer, Serial Number, and Product Name. A 'Refresh' button is located to the right of this table. The next section is 'Mounted Devices' with a table with columns: Mount Path, File System, Total Size, Used Space, Free Space, Percentage Usage, and Actions. Another 'Refresh' button is located to the right of this table.

**Figure 4.3.6 USB/SATA**

### 4.3.7 Device Management

Device Management allows you to view and configure parameters relating to the device's association with an ACS.

The screenshot shows a web interface for Device Management. On the left is a navigation menu with 'Basic' and 'Advanced' sections. Under 'Advanced', 'Device Management' is selected. The main content area is titled 'Device Management' and contains a 'Settings' section. The settings are organized into two columns. The left column includes: 'CWMP Enable' (checked), 'ACS Username' (qa cafe), 'Connection Request URL' (http://127.0.0.1:8000), 'Connection Request Password' (masked), 'Periodic Inform Interval' (3600), 'Upgrades Managed' (unchecked), and 'CWMP Retry Interval Multiplier' (2000). The right column includes: 'ACS URL' (http://6.0.0.1:80/), 'ACS Password' (masked), 'Connection Request Username' (qa cafe), 'Periodic Inform Enable' (ON), 'Periodic Inform Time' (0001-01-01T00:00:00Z), and 'CWMP Retry Minimum Wait Interval' (5). At the bottom right are three buttons: 'Modify', 'Reset', and 'Send Inform'.

**Figure 4.3.7 Device Management**

## **Appendix A: Cable Requirements**

### **A.1 Ethernet Cable**

A CAT 3~7 UTP (unshielded twisted pair) cable is typically used to connect the Ethernet device to the Modem. A: 10/100TX cable often consists of four pairs of wires, two of which are used for transmission. The connector at the end of the 10/100TX cable is referred to as a RJ-45 connector and it consists of eight pins. The Ethernet standard uses pins 1, 2, 3 and 6 for data transmission purposes. (Table A-1 10/100TX)

B: 1000TX cable often consists of four pairs of wires, all of which are used for transmission. The connector at the end of the 1000TX cable is referred to as a RJ-45 connector and it consists of eight pins. The Ethernet standard uses pins 1, 2, 3, 4, 5 and 6 for data transmission purposes. (Table A-1 1000TX)

**Table A-1** RJ-45 Ethernet Connector Pin Assignments

PIN #	10/100TX		1000TX	
	Signal	Media Dependant interface	Signal	Media Dependant interface-cross
1	TX+	Transmit Data+	BI_DA+	Bi-directional pair A+
2	TX-	Transmit Data-	BI_DA-	Bi-directional pair A-
3	RX+	Receive Data+	BI_DB+	Bi-directional pair B+
4	NC	Unused	BI_DC+	Bi-directional pair C+
5	NC	Unused-	BI_DC-	Bi-directional pair C-
6	RX-	Receive Data-	BI_DB-	Bi-directional pair B-
7	NC	Unused	BI_DD+	Bi-directional pair D+
8	NC	Unused	BI_DD-	Bi-directional pair D-

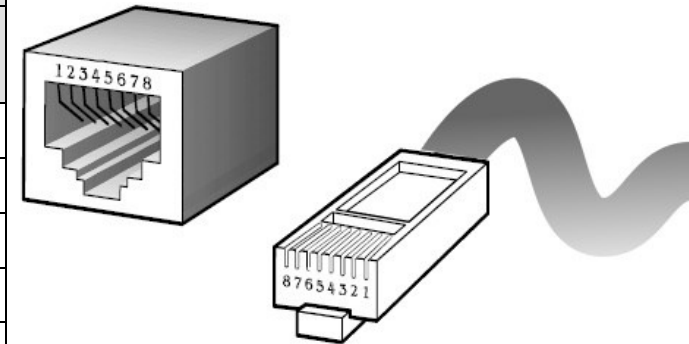

**Figure A-1** Standard RJ-45 receptacle/connector

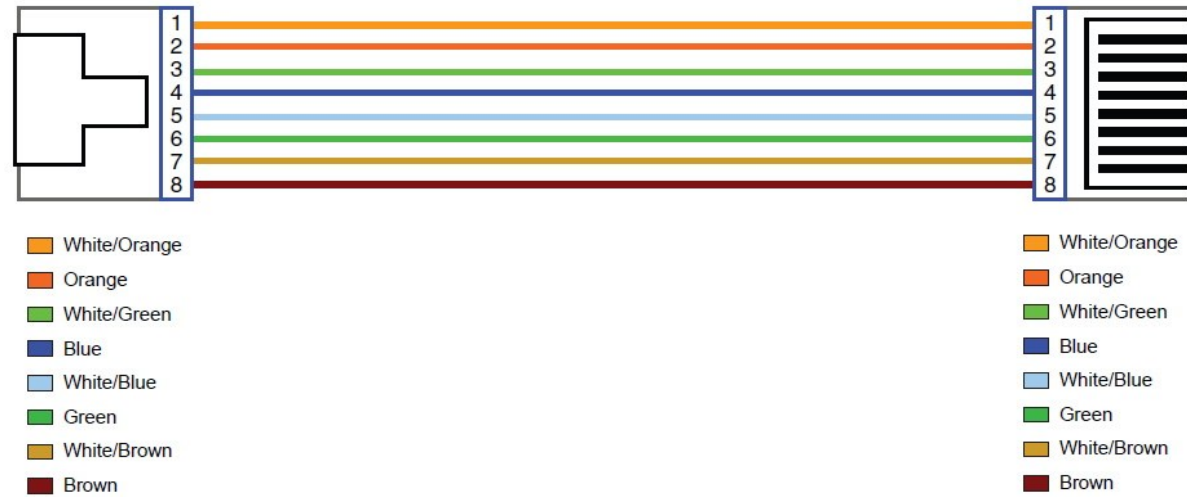

**Figure A-2 Pin Assignments and Wiring for an RJ-45 Straight-Through Cable**



**Figure A-3 Pin Assignments and Wiring for an RJ-45 Crossover Cable**

**A.2 Telephone wire**

Standard telephone wire of any gauge or type-flat, twisted or quad is used to connect the Modem to the telephone network. A telephone cable typically consists of three pairs of wires, one of which is used for transmission. The connector at the end of the telephone cable is called an RJ-11 connector and it consists of six pins. POTS (plain old telephone services) use pins 3 and 4 for voice transmission. A telephone cable is shown below. (Figure A-4)

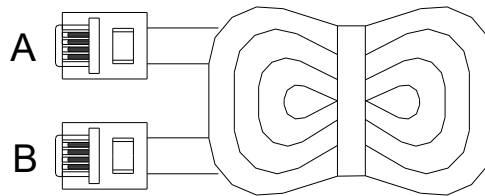

**Figure A-4 Telephone cable.**

The A and B connectors on the rear of the Modem are RJ-11 connectors. These connectors are wired identically. The RJ-11 connectors have six positions, two of which are wired. The Modem uses the center two pins. The pin out assignment for these connectors is presented below. (Table A-2)

**Table A-2 RJ-11 Pin out Assignments.**

Pin#	MNEMONIC	FUNCTION
1	NC	Unused
2	NC	Unused
3	TIP	POTS
4	RING	POTS
5	NC	Unused
6	NC	Unused

## **Appendix B: Product Specifications**

### **Key Features & Benefits**

- ◆ Compliant with IEEE 802.3 / 802.3u / 802.3ab Ethernet Standard
- ◆ Compliant with ITU-T G993.2 VDSL2 standard (NV-450S only)
- ◆ Compliant with ITU-T G998.4 G.INP standard (NV-450S only)
- ◆ Compliant with ITU-T G.9700/G.9701 G.fast standard
- ◆ Backward compatible ADSL/VDSL2/V35b (NV-450S only)
- ◆ Support 106a & 212a dual G.fast band profile
- ◆ Support super Vectoring for V35b / G.fast(NV-450S only)
- ◆ Support Vectoring for VDSL2(NV-450S only)
- ◆ Support High Bandwidth up to 1Gbps.
- ◆ Support USB 3.0 for connecting USB Dongle
- ◆ Support static routing for IPv4 and IPv6 forwarding (NV-450S only)
- ◆ Support 8 queue MFC/DSCP both type QoS
- ◆ Support HTTP/HTTPS web management.
- ◆ Support SSL security.
- ◆ Support remote management and monitor.
- ◆ Support configuration backup and restore.
- ◆ On board surge protection for Line port
- ◆ Support bridge(switch) / Router mode (NV-450M bridge mode only)
- ◆ Support Dual Firmware Image Backup
- ◆ Support NTP Time Server.
- ◆ Support TR-0693.

**NV-450M/S: G.fast Master Modem+ G.fast / VDSL2 / V35b Slave Modem USER'S MANUAL Ver. A.9**

- ◆ Support RJ-11 / Terminal block combo Line port.
- ◆ On board POTS/ISDN splitter
- ◆ Support Jumbo frame (MTU) up to 1600 bytes.

**Note:**

1. Features and specifications in this manual are subject to change without prior notice.
2. (\*) Firmware is upgradable for future enhancement.

## Product Specification

<b>Standard:</b>	IEEE802.3/802.3u/802.3ab standards ITU-T G9700/G9701 standards ITU-T G993.2/G998.4 standards (NV-450S only)
<b>Regulatory Compliance:</b>	FCC CE RoHS Compliance
<b>Physical Interface:</b>	4 x RJ-45 10/100/1000 Mbps Ethernet port 1 x RJ-11 / Terminal block combo for line port 1 x RJ-11 connector for POTS/ISDN phone device 1 x Reset Button for resetting to factory default. 2 x USB3.0 for connecting USB dongle
<b>LED Indicators:</b>	1 x Power LED 4 x Link/Active Status for Ethernet port 1 x Link LED for G.fast mode 1 x Link LED for xDSL mode (NV-450S only) 1 x Master (CO) LED (NV-450M only)
<b>Switch method:</b>	Store and forward
<b>Flow control:</b>	Full duplex: IEEE 802.3x Half duplex: Back pressure
<b>Typical Power Consumption:</b>	NV-450M: 7.92W (Full load, without USB port) 17.92W(Full load, with 2 x USB port)

**NV-450M/S: G.fast Master Modem+ G.fast / VDSL2 / V35b Slave Modem USER'S MANUAL Ver. A.9**

	NV-450S: 8.16W(Full load, without USB port) 18.16W(Full load, with 2 x USB port)
<b>Power Supply:</b>	Input Voltage: 12 VDC (Commercial-grade power adapter)
<b>Operating Temperature:</b>	0°C ~ 50°C (32°F ~ 122°F)
<b>Storage Temperature:</b>	0°C ~ 50°C (32°F ~ 122°F)
<b>Humidity:</b>	10% to 90% (non-condensing)
<b>Dimensions:</b>	196 x 146 x 40 mm (7.2" x 5.74" x 1.57")
<b>Weight:</b>	approX.0.4 kg
<b>EMC Certification:</b>	EMI Compliant: FCC EMS Compliant: CE mark

## **Appendix C: Troubleshooting**

### **Diagnosing the Modem's Indicators**

The modem can be easily monitored through its comprehensive panel indicators. These indicators assist the network manager in identifying problems the hub may encounter. This section describes common problems users may encounter and possible solutions.

<b>1. Symptom:</b>	POWER indicator does not light up (green) after power on.
<b>Cause:</b>	Defective External power supply
<b>Solution:</b>	Check the power plug by plugging in another that is functioning properly. Check the power cord with another device. Check the terminal block and make sure to fasten the power cord. If these measures fail to resolve the problem, have the unit power supply replaced by a qualified distributor?

<b>2. Symptom:</b>	NV-450M/S both cannot handshaking after making a connection.
<b>Cause:</b>	Network interface (ex. a network adapter card on the attached device), network cable, or switch port is defective.
<b>Solution:</b>	<ol style="list-style-type: none"><li>2.1 Verify that the switch and attached device are power on.</li><li>2.2 Be sure the cable is plugged into both the switch and corresponding device.</li><li>2.3 Verify that the proper cable type is used, and its length does not exceed specified limits.</li><li>2.4 Check the modem on the attached device and cable connections for possible defects.</li><li>2.5 Make sure that the phone wire must be connecting NV-450S first, when powered on.</li><li>2.6 Replace the defective modem or cable if necessary.</li><li>2.7 Checking Phone wire length if exceed 600m(1968ft)</li></ol>

**NV-450M/S: G.fast Master Modem+ G.fast / VDSL2 / V35b Slave Modem USER'S MANUAL Ver. A.9**

<b>3. Symptom:</b>	Line Link cannot be established.
<b>Cause:</b>	NV-450M/ NV-450S setting failure or phone cable length is over the specification limit(600m=1968ft).
<b>Solution:</b>	3.1 Please make sure that the phone wire must be connected between NV-450M(Master) side and NV-450S(Slave) side when both are power on. NV-450M Master side will do link speed function depending on phone wire length, therefore if NV-450M Master side can't detect Slave Side over phone wire while both power on, this will cause the Link to fail. 3.2 Please check phone wire, we recommend using 24-26 gauge with twisted pair and without rust. 3.3 Please reinsert power when changing cable length or link time over 3 minutes. 3.4 If NV-450S connects to IP-DSLAM and link failure, please try to change band profile to 17a to get long reach.
<b>Note:</b>	Phone wire must meet CAT. 3 or above twisted pairs, otherwise will cause more crosstalk and return loss issue hence to reduce Line power driving.

<b>4. Question:</b>	I just bought a pair of NV-450S/ NV-450S to replace my Quest DSL modem for my home. I was told any G.fast modem would replace and give me higher communication speeds. It doesn't get users on the internet when hooked up. All lights come on but no Link light. Is this the completely wrong application for this unit?
<b>Answer:</b>	Re: Please note NV-450S is a Slave (CPE side), it must be connected to the NV-450M Master (CO side) or IP-DSLAM to get link.

<b>5. Question:</b>	We need to set up a default gateway on a NV-450M/ NV-450S pair which are in Bridge mode, as they want to manage the units from a different network.
<b>Answer:</b>	<p>When the application is used within the LAN, the switch(bridged) mode is not necessary to set up a gateway. However, if the application crosses various network segments (LAN to WAN(Line) or WAN(Line) to LAN), users must set up a gateway to connect different network segment.</p> <p>Regarding how to configure a default gateway at switch(bridged) mode for crossing various network segments.</p> <p>Configuration gateway example from <b>Static Routing</b>:</p> <p>Destination LAN IP: <b>0.0.0.0</b></p> <p>Subnet Mask: <b>0.0.0.0</b></p> <p>Gateway: <b>192.168.16.1</b></p> <p><b>Note:</b> Static Routing functionality is used to define the connected Gateway between the LAN and WAN.</p>

<b>6. Question:</b>	What can I do if I forgot my password.
<b>Answer:</b>	<p>If users forgot user's password, users must reset user's modem. Unfortunately, this process will change all user's settings back to the factory defaults. To reset the modem, locate the reset on the rear panel of the unit. With the modem powered on, use a paperclip to hold the button down for over 5 seconds. Release the button and the modem will go through its reboot process. NV-450M default ip is 192.168.16.249. NV-450S default ip is 192.168.16. 254. When logging in, the default username and password both are "admin".</p>

<b>7. Question:</b>	What is the maximum Ethernet frame MTU for these modems?
<b>Answer:</b>	NV-450M / NV-450S Jambo frame (MTU) up to 1600 bytes.

## **System Diagnostics**

### **Power and Cooling Problems**

If the POWER indicator does not turn on when the power cord is plugged in, users may have a problem with the power outlet, power cord, or internal power supply as explained in the previous section. However, if the unit power is off after running for a while, check for loose power connections, power losses or surges at the power outlet. If users still cannot isolate the problem, then the internal power supply may be defective. In this case, please contact the user's local dealer.

### **Installation**

Verify that all system components have been properly installed. If one or more components appear to be malfunctioning (e.g. the power cord or network cabling), test them in an alternate environment where users are sure that all the other components are functioning properly.

### **Transmission Mode**

The default method of selecting the transmission mode for RJ-45 Ethernet ports is 10/100/1000 Mbps, for RJ-11-line port are auto-follow CO side band profile for NV-450S. Therefore, if the Link signal is disrupted (e.g. by unplugging the network cable and plugging it back in again, or by resetting the power), the port will try to reestablish communications with the attached device via auto-negotiation. If auto-negotiation fails, then communications are set to half duplex by default. Based on this type of commercial-standard connection policy, if user's are using a full-duplex device that does not support auto-negotiation, communications can be easily lost (i.e. reset to the wrong mode) whenever the attached device is reset or experiences a power fluctuation. The best way to resolve this problem is to upgrade these devices to a version that supports Ethernet auto-negotiation.

### **Physical Configuration**

If problems occur after altering the network configuration, restore the original connections, and try to track the problem down by implementing the latest changes, one step at a time. Ensure that cable distances and other physical aspects of the installation do not exceed recommendations.

### **System Integrity**

As a last resort verify the switch integrity with a power-on reset. Turn the power to the switch off and then on several times. If the problem still persists and users have completed all the preceding diagnoses, then contact the user's dealer.

## **Appendix D: Compliance Information**

### **FCC Radio Frequency Interference Statement**

This equipment has been tested and found to comply with the limits for a computing device, pursuant to Part 15 of FCC rules. These limits are designed to provide reasonable protection against harmful interference when the equipment is operated in a commercial environment. This equipment generates uses and can radiate radio frequency energy and, if not installed and used in accordance with the instructions, may cause harmful interference to radio communications. However, there is no guarantee that interference will not occur in a particular installation. If this equipment does cause harmful interference to the radio or television reception, which can be determined by turning the equipment off and on, the user is encouraged to try to correct the interference by one or more of the following measures:

1. Reorient or relocate the receiving antenna.
2. Increase the separation between the equipment and receiver.
3. The equipment and the receiver should be connected to outlets on separate circuits.
4. Consult the dealer or an experienced radio/television technician for help.

Changes or modifications not expressly approved by the party responsible for compliance could prevent the user's authority to operate the equipment.

If this telephone equipment causes harm to the telephone network, the telephone company will notify users in advance that temporary discontinuance of service may be required. But if advance notice isn't practical, the telephone company will notify the customer as soon as possible. Also, users will be advised of the user's right to file a complaint with the FCC if users believe it is necessary.

**NV-450M/S: G.fast Master Modem+ G.fast / VDSL2 / V35b Slave Modem USER'S MANUAL Ver. A.9**

The telephone company may make changes in its facilities, equipment, operations, or procedures that could affect the proper functioning of the user's equipment. If they do, users will be notified in advance in order to make necessary modifications to maintain uninterrupted service.

This equipment may not be used on the coin service provided by the telephone company. Connection to party lines is subject to state tariffs.

**FCC Warning**



This equipment has been tested to comply with the limits for a **Class A** digital device, pursuant to Part 15 of the FCC Rules. These limits are designed to provide reasonable protection against harmful interference when the equipment is operated in a commercial environment. This equipment can generate, use, and radiate radio frequency energy and, if not installed and used in accordance with the instruction manual, may cause harmful interference to radio communications. Operation of this equipment in a residential area is likely to cause harmful interference in which case the user will be required to correct the interference at owner's expense.

**CE Mark Warning**



**This is a class A product.** In a domestic environment, this product may cause radio interference in which case the user may be required to take adequate measures.

**RoHS Mark Warning**



RoHS stands for Restriction of Hazardous Substances and impacts the entire electronics industry and many electrical products as well. The original RoHS, also known as Directive 2002/95/EC, originated in the European Union in 2002 and restricts the use of six hazardous materials found in electrical and electronic products. All applicable products in the EU market from July 1, 2006, must pass RoHS compliance. Directive 2011/65/EU was published in 2011 by the EU, which is known as RoHS-Recast or RoHS 2. RoHS 2 includes a **CE-marking directive**, with RoHS compliance now being required for CE marking of products. RoHS 2 also added Categories 8 and 9 and has additional compliance recordkeeping requirements. Directive 2015/863 was published in 2015 by the EU, which is known as RoHS 3. RoHS 3 adds four additional restricted substances (phthalates) to the list of six.

**WEEE Warning**



To avoid the potential effects on the environment and human health as a result of the presence of hazardous substances in electrical and electronic equipment, end users of electrical and electronic equipment should understand the meaning of the cross-out wheeled bin symbol. Do not dispose of WEEE in unsorted municipal waste and have to collect such WEEE separately.

## **ErP Power Usage**

This device is an Energy Related Product (ErP) with High Network Availability (HiNA). If it is not needed during certain periods of time, it can be unplugged to save energy.

Network Standby: NV-450M 5.7 watts.  
                          NV-450S 5.6 watts

## **Warranty**

The original product that the owner delivered in this package will be free from defects in material and workmanship for one-year parts after purchase.

There will be a minimal charge to replace consumable components, such as fuses, power transformers, and mechanical cooling devices. The warranty will not apply to any products which have been subjected to any misuse, neglect or accidental damage, or which contain defects which are in any way attributable to improper installation or to alteration or repairs made or performed by any person not under control of the original owner.

The above warranty is in lieu of any other warranty, whether express, implied, or statutory, including but not limited to any warranty of merchantability, fitness for a particular purpose or any warranty arising out of any proposal, specification or sample. We shall not be liable for incidental or consequential damages. We neither assume nor authorize any person to assume for it any other liability.

**WARNING**  
Warranty Void  
If Removed

### **WARNING:**

- 1.DO NOT TEAR OFF OR REMOVE THE WARRANTY STICKER AS SHOWN, OR THE WARRANTY IS VOID.**
- 2.WARRANTY VOID IF USE COMMERCIAL-GRADE POWER ADAPTER IS USED AT HARSH ENVIRONMENTS.**

**Chinese SJ/T 11364-2024**

部件名称	有毒有害物质或元素									
	铅(Pb)	汞(Hg)	镉(Cd)	六价铬 [Cr(VI)]	多溴联苯 (PBB)	多溴二苯 醚(PBDE)	邻苯二甲 酸二(2- 乙基己 基)酯 (DEHP)	邻苯二甲 酸丁酯苯 甲酯 (BBP)	邻苯二甲 酸二丁酯 (DBP)	邻苯二甲 酸二异丁 酯 (DIBP)
结构壳体	○	○	○	○	○	○	○	○	○	○
电路组	○	○	○	○	○	○	○	○	○	○
电源供应器	○	○	○	○	○	○	○	○	○	○
线材	○	○	○	○	○	○	○	○	○	○
包装及配件	○	○	○	○	○	○	○	○	○	○
○：表示该有毒物质在该部件所有均质材料中的含量均在 GB/T 39560 标准规定的限量要求以下。 ×：表示该有毒物质至少在该部件的某依均质材料中的含量超出 GB/T 39560 标准规定的限量要求。										

上述规范仅适用于中国法律