

The background features a stylized globe with a grid of latitude and longitude lines, overlaid with a network of glowing blue lines and nodes. The overall color scheme is dominated by various shades of blue, from light sky blue to deep navy blue.

netsys

Networking your world

NV-520G

**Industrial 4 Giga LAN Over VDSL2
Extender with DIP Switch**

USER'S MANUAL

[Http://www.netsys.com.tw](http://www.netsys.com.tw)



Copyright

Copyright © 2023 by National Enhance Technology Corp. All rights reserved.

Trademarks

NETSYS is a trademark of National Enhance Technology Corp.

Other brands and product names are registered trademarks or trademarks of their respective holders.

Legal Disclaimer

The information given in this document shall in no event be regarded as a guarantee of conditions or characteristics. With respect to any examples or hints given herein, any typical values stated herein and/or any information regarding the application of the device, National Enhance Technology Corp. hereby disclaims any and all warranties and liabilities of any kind, including without limitation warranties of non-infringement of intellectual property rights of any third party.

Statement of Conditions

In the interest of improving internal design, operational function, and/or reliability, NETSYS reserves the right to make changes to the products described in this document without notice. NETSYS does not assume any liability that may occur due to the use or application of the product(s) or circuit layout(s) described herein.

Maximum signal rate derived from IEEE Standard specifications. Actual data throughput will vary. Network conditions and environmental factors, including volume of network traffic, building materials and construction, and network overhead, lower actual data throughput rate. Netsys does not warrant that the hardware will work properly in all environments and applications, and makes no warranty and representation, either implied or expressed, with respect to the quality, performance, merchantability, or fitness for a particular purpose. Make sure you follow in line with the environmental conditions to use this product.

Foreword: Ethernet extender for industrial-grade solution

Attention:

Be sure to read this manual carefully before using this product. Especially Legal Disclaimer, Statement of Conditions and Safety Warnings.

Netsys' NV-520G is a VDSL2 line port over 4 x Giga Ethernet ports that provide an economical solution for your industrial applications. Compliant with ITU-T G.993.2 VDSL2 standard, the NV-520G supports a maximum bandwidth of up to 160Mbps symmetric in VDSL2 Profile (35b) solution. The NV-520G also supports both CO (Master) and CPE (Slave) modes selectable through DIP Switch.

NV-520G support DIN-Rail and Industrial-grade design compliant with quick, easy, economical, and high-performance broadband/multimedia services to industrial environments such as IP surveillance, Factory auto control, MRT, Train station, Weather station, Ticket vending machine, Parking system, Monitoring system, Farm, Ship, Jail etc. point to point applications.

Caution:

The NV-520G is an industrial-grade application. This product does not have waterproof protection.

Safety Warnings

For your safety, be sure to read and follow all warning notices and instructions before using the device.

- ◆ **DO NOT** open the device or unit. Opening or removing the cover may expose you to dangerous high voltage points or other risks. ONLY qualified service personnel can service the device. Please contact your vendor for further information.
- ◆ **Use ONLY** the dedicated power supply for your device. Connect the power to the right supply voltage (110V AC used for North America and 230V AC used for Europe. NV-520G supports 15 to 48 VDC dual power input (Redundant power).
- ◆ **Place** connecting cables carefully so that no one will step on them or stumble over them. DO NOT allow anything to rest on the power cord and do NOT locate the product where anyone can work on the power cord.
- ◆ **DO NOT** install nor use your device during a thunderstorm. There may be a remote risk of electric shock from lightning.
- ◆ **DO NOT** expose your device to dampness, dust or corrosive liquids.
- ◆ **DO NOT** use this product near water, for example, in a wet basement or near a swimming pool.
- ◆ **Connect ONLY** suitable accessories to the device.
- ◆ **Make sure** to connect the cables to the correct ports.
- ◆ **DO NOT** obstruct the device ventilation slots, as insufficient air flow may harm your device.
- ◆ **DO NOT** place items on the device.
- ◆ **DO NOT** use the device for outdoor applications directly, and make sure all the connections are indoors or have waterproof protection place.
- ◆ **Be careful** when unplugging the power, because it may produce sparks.
- ◆ **Keep** the device and all its parts and accessories out of the reach of children.
- ◆ **Clean** the device using soft and dry cloth rather than liquid or atomizers. Power off the equipment before cleaning it.
- ◆ This product is **recyclable**. Dispose of it properly.

TABLE OF CONTENTS

COPYRIGHT	1
FOREWORD: ETHERNET EXTENDER FOR INDUSTRIAL-GRADE SOLUTION	2
SAFETY WARNINGS	3
1.1 Check List	6
CHAPTER 2. INSTALLING NV-520G	7
2.1 Hardware Installation.....	7
2.2 Pre-installation Requirements	7
2.3 General Rules	8
2.4 Connecting NV-520G	9
2.5 Terminal Block and DIN-Rail mount installation.....	10
2.6 Connecting the RJ-11 / RJ-45 Ports	11
2.7 Industrial NV-520G Application	13



CHAPTER 3: HARDWARE DESCRIPTION	15
3.1 Front Panel.....	16
3.2 Front Indicators	21
3.3 Rear Panel	22
3.4 Side Panel	22
APPENDIX A: CABLE REQUIREMENTS	28
APPENDIX B: PRODUCT SPECIFICATION	30
APPENDIX C: TROUBLESHOOTING	33
APPENDIX D: IP-30 PROTECTION OF METAL CASE	39
TABLE D-2 SECOND DIGIT: PROTECTION GRADES FOR WATER PROTECTION.....	40
APPENDIX E: COMPLIANCE INFORMATION	41
WARRANTY	45
CHINESE SJ/T 11364-2024	46

CHAPTER 1. UNPACKING INFORMATION

1.1 Check List

Carefully unpack the package and check its contents against the checklist.

Package Contents:

	
<p>1 x NV-520G device</p>	<p>Accessory Kit: 1 x DIN-Rail mounting plate, 2 x screws, 4 x Rubber Feet, Protective caps (RJ-11*1, RJ-45*3), 1 x 6pin Terminal Block, 1 x 2pin Terminal Block</p>

Notes:

1. Please inform your dealer at once of any missing or damaged parts. If possible, keep the carton including the original packing materials. Use them to repack the unit in case there is a need to return for repair.
2. If the product has any issues, please contact your local distributor.
3. Please use the provided protective caps for unused ports.
4. Please look for the QR code on the bottom of the product, the user can launch the QR code scanning program to scan and download the user's manual electronic format file. Above QR code icon is for reference.
5. Power Input: This model supports 15~48V DC power adapters with recommended 15 Watts or above.

Chapter 2. Installing NV-520G

Caution:

Please equip the anti-static devices during INSTALLATION.

2.1 Hardware Installation

This chapter describes how to install NV-520G and establish network connections. NV-520G may be installed on any level surface (eg. a table or shelf). However, please take note of the following minimum site requirements before you begin.

2.2 Pre-installation Requirements

Before you start the actual hardware installation, make sure you can provide the right operating environment, including power requirements, sufficient physical space, and proximity to other network devices that are to be connected.

Verify the following installation requirements:

- Power requirements: **DC 15 to 48VDC redundant power.**
- The NV-520G should be located in a cool dry place, with at least **10cm/4in** of space at the front and back for ventilation.

- Place NV-520G away from direct sunlight, heat sources, or areas with a high amount of electromagnetic interference.
- Check if the network cables and connectors needed for installation are available.
- Do not install phone lines strapped together with AC power lines, or telephone office line with voice signal.
- Avoid installing this device with radio amplifying stations nearby or transformer stations nearby.

2.3 General Rules

Before making any connections to the NV-520G, please note the following rules:

- **Ethernet Port (RJ-45)**

All network connections to the NV-520G Ethernet ports must be made using Category 5 UTP/STP or above for 100/1000 Mbps, Category 3, 4 UTP for 10Mbps.

No more than 100 meters of cabling may be used between MUX or Ethernet Switch and an end node.

- **Line Port (RJ-11)**

All network connections to the RJ-11port must use **24~26** gauge with **twisted pair** phone wiring.

We **do not recommend** the use of the telephone line 28 gauge or above.

The RJ-11 connectors have six positions, two of which are wired. The NV-520G uses the center two pins.

The pin out assignment for these connectors is presented below.

Please note that the line port is without polarity, therefore users can reverse the two wires of the phone cable when installed.

RJ-11 Pin out Assignments

Pin#	MNEMONIC	FUNCTION
1	NC	Unused
2	NC	Unused
3	DSL	Used
4	DSL	Used
5	NC	Unused
6	NC	Unused_

2.4 Connecting NV-520G

NV-520G has four Ethernet ports which support connection to Ethernet operation. The devices attached to these ports must support auto-negotiation /10Base-T / 100Base-TX / 1000Base-TX unless they always run at half duplex. Use any of the Ethernet ports to connect networking devices such as Monitor systems, Servers, Ethernet Switches.

Notes:

1. The (RJ11/Terminal Block) Line port is used to connect the telephone that is connected to both NV-520G between CO and CPE mode (Point-to-point solution).
2. Use the provided protective caps for unused ports to avoid dust intrusion.
3. The Slave device (CPE) must be connected to the Master device (CO) through the telephone wire. The Slave cannot be connected to another Slave, and the Master cannot be connected to another Master.

2.5 Terminal Block and DIN-Rail mount installation

This section describes how to install the Terminal Block and DIN-Rail to the NV-520G, if you do not install the DIN-Rail, please paste the 4 rubber feet at the bottom of the hulled to avoid scratches of metal housing.

- ◆ Take out the “2pin / 6pin terminal block” from inside the accessory kit and install to the NV-520G properly. (Figure 2.5.1)
- ◆ Please refer to installing the DIN-RAIL as following step:
 1. Install the DIN-Rail mounting plate to the NV-520G. (Figure 2.5.2)
 2. Please use the suitable DIN-Rail to install, please refer to the dimensions of the DIN-Rail. (Figure 2.5.3)
 3. Insert the top of the DIN-Rail into the top slots on the DIN-Rail mounting plate and the DIN-Rail mounting plate will snap into place. (Figure 2.5.4)

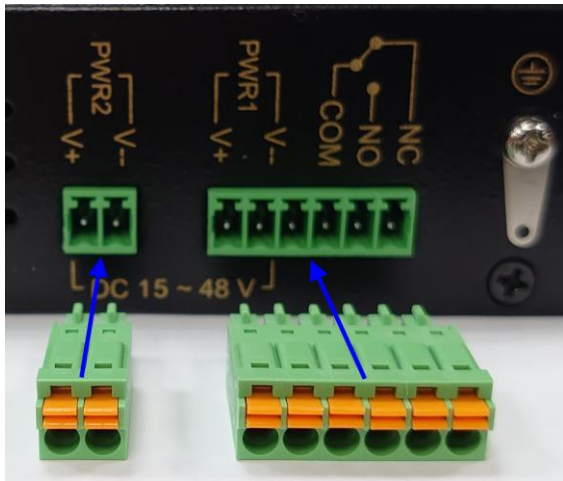

Figure 2.5.1

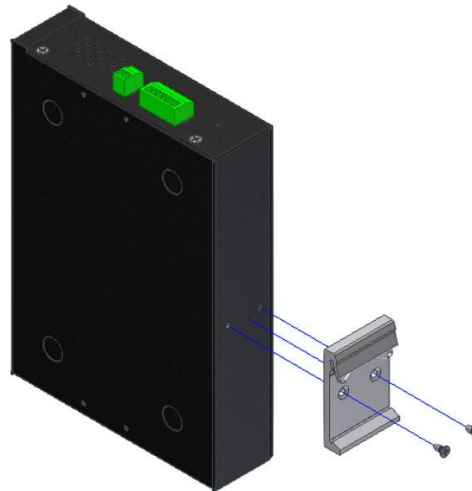

Figure 2.5.2

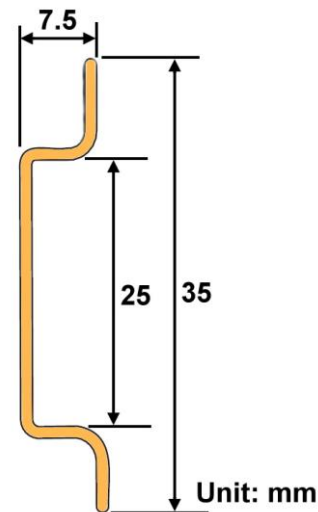

Figure 2.5.3

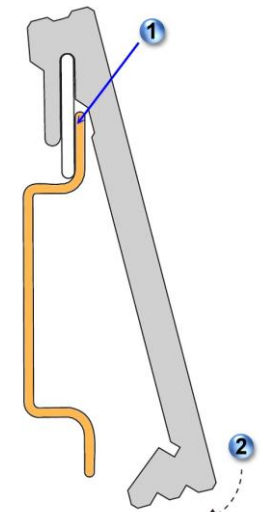

Figure 2.5.4

2.6 Connecting the RJ-11 / RJ-45 Ports

- ◆ The Line port has 2 connectors: RJ-11 and terminal block. It is used to connect from NV-520G (CO) over single pair phone cable to NV-520G (CPE) line port (point to point solution). Take note that NV-520G line port cannot be used at the same time. Either RJ-11 port is connected or terminal block is connected using straight connection (Figure 2.6.1) or cross-over connection (Figure 2.6.2)

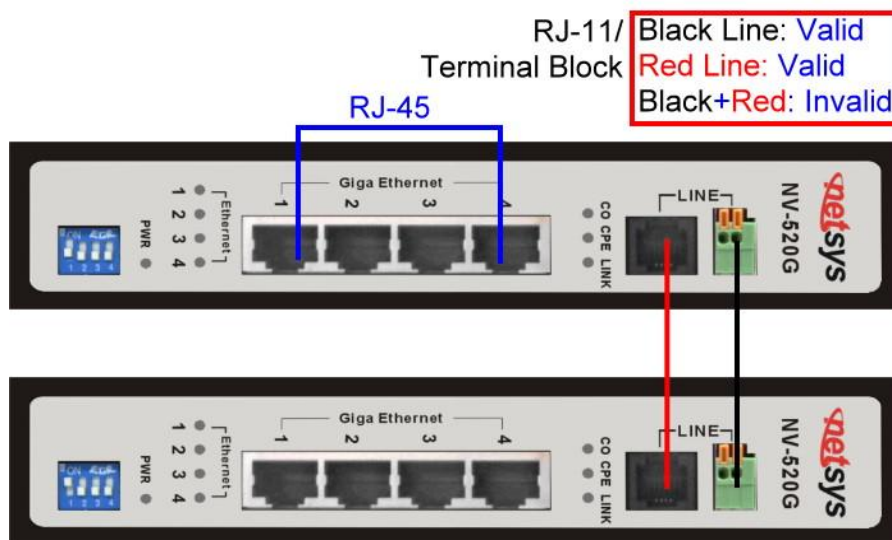

Figure 2.6.1 NV-520G line ports straight connection

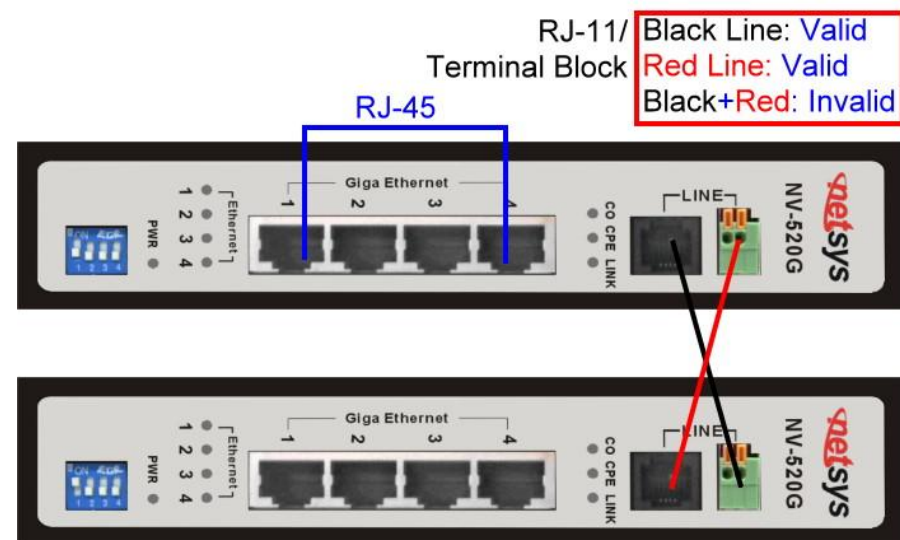

Figure 2.6.2 NV-520G line ports crossover connection

- ◆ When inserting a RJ-11 plug, make sure the tab on the plug clicks into position to ensure that it is properly seated.
- ◆ **Do not** plug an RJ-11 phone jack connector into the Ethernet port (RJ-45 port). This may damage NV-520G. Instead, use only twisted-pair cables with RJ-45 connectors that conform to Ethernet standard.

Notes:



NV-520G Industrial grade LAN Extender USER'S MANUAL Rev. A.9

1. Be sure each twisted-pair cable (RJ-45 Ethernet cable) does not exceed 100 meters (333 feet).
2. We advise using Category 5~7 UTP/STP cables for making Networking device or NV-520G connections to avoid any confusion or inconvenience in the future when you attach high bandwidth devices.
3. Use **24 ~ 26** gauge twisted pair phone wiring, we do not recommend 28 gauge or above.
4. Be sure phone wire has been installed before the NV-520G boot.

2.7 Industrial NV-520G Application

NV-520G's line port supports 100Mbps for data service across existing phone wiring. It is easy-to-use which do not require installation of additional wiring. Every modular phone jack in the home can become a port on the LAN. Networking devices can be installed on a single telephone wire that can be installed within a suitable distance (depending on speed) (Figure 2.6)

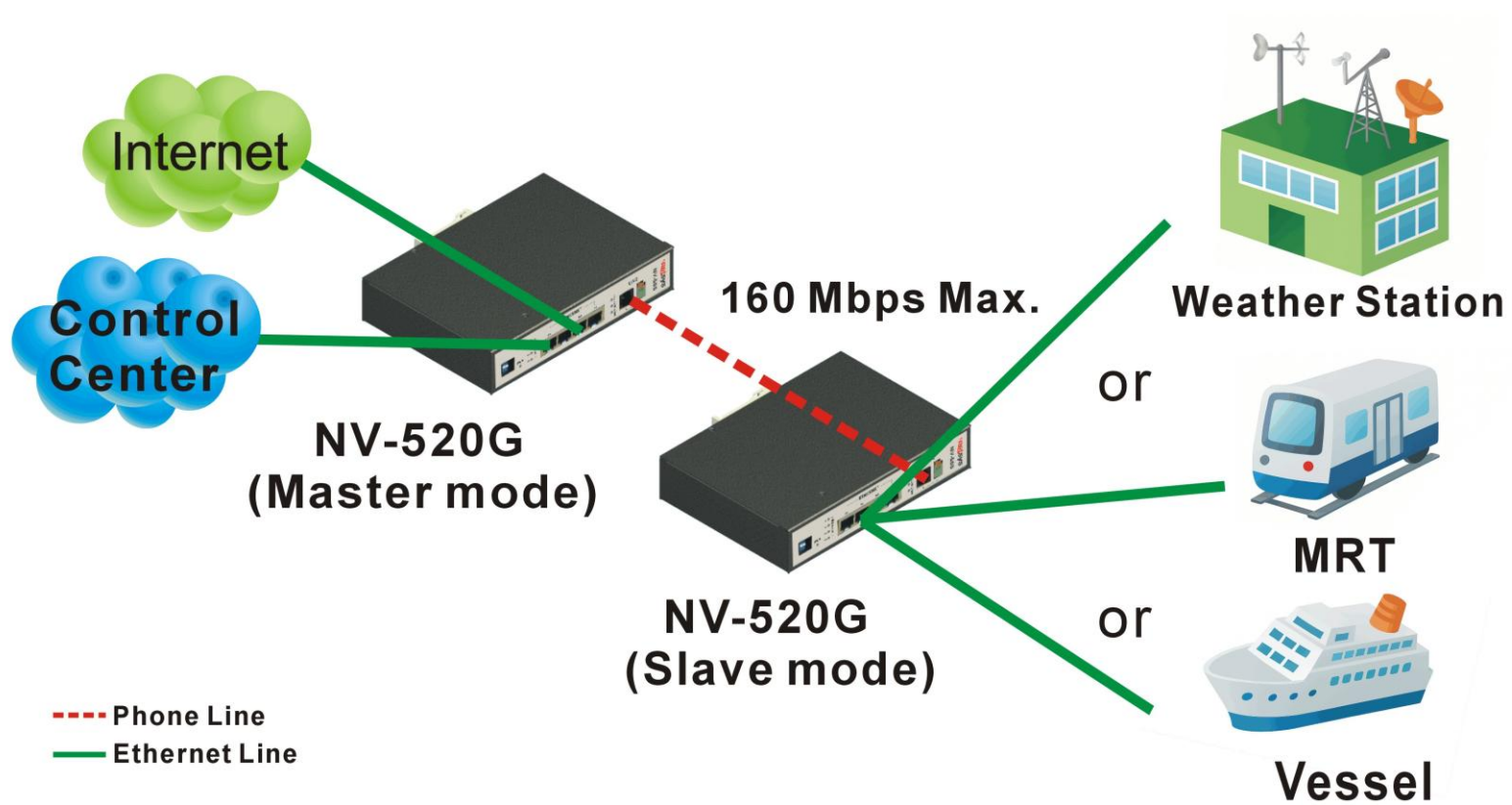

Figure 2.6 NV-520G point to point application

Application

— Phone Wiring
— Ethernet Cable

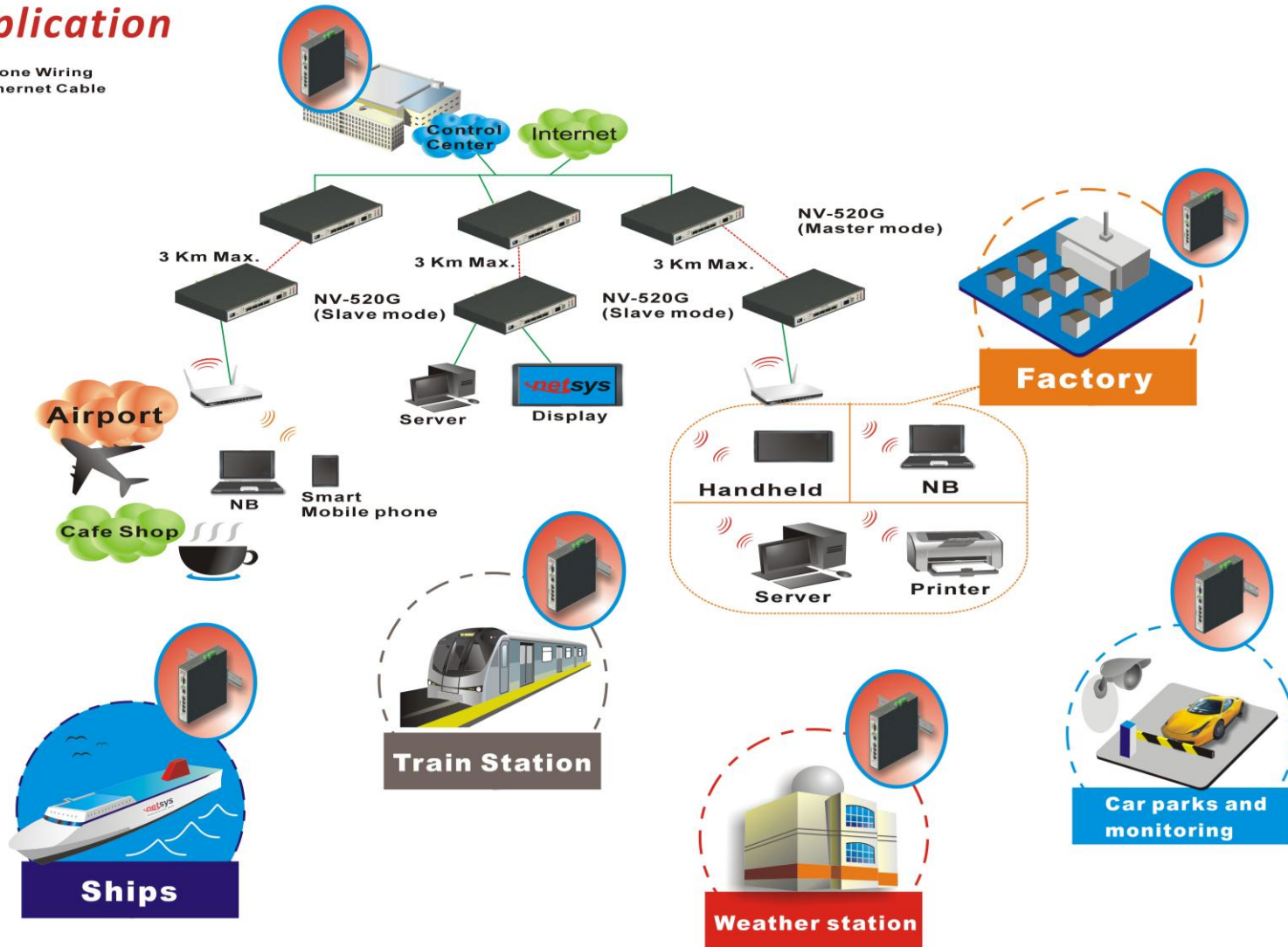
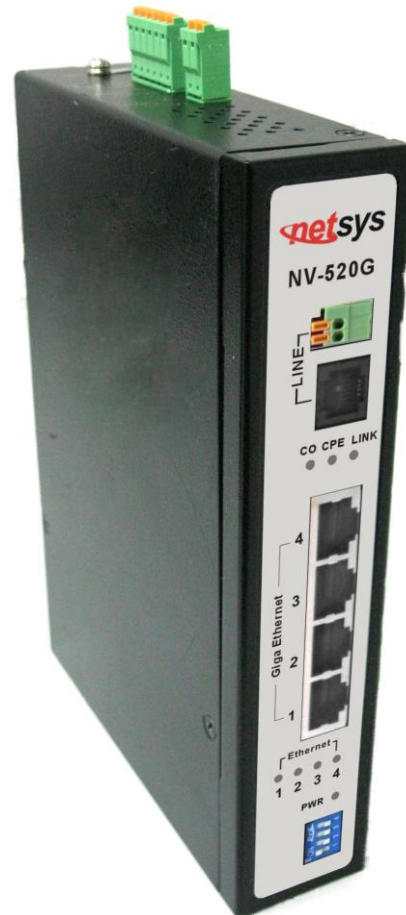

Figure 2.7 NV-520G industrial-grade application

Chapter 3. Hardware Description

The front panel provides a simple interface monitoring of NV-520G. It features the front panel, side panel and rear panel.



NV-520G Outward

3.1 Front Panel

The figure shows the front panel. (Figure 3.1)



Figure 3.1 Front Panel

Tip:

At a quick glance of the front panel, it is easy to tell if it has Ethernet signal from its RJ-45 port and if there is vdsl line signal on RJ-11 port.

And the table shows the description. (Table 3-1)

Table 3-1 Description of NV-520G front connectors

Connectors	Type	Description
DIP Switch	4 Pins DIP Switch	Provide 4 selectable transmission modes.
Ethernet	RJ-45	For connecting to an Ethernet equipped device.
Line	RJ-11/Terminal Block	For connecting to NV-520G. (Do not use RJ11 and Terminal Block at the same time.)

The following figure shows the DIP switch connection. By switching the transmission modes, you can obtain the best transmission mode to suit phone line quality or distance or connectivity. (Figure 3.2)

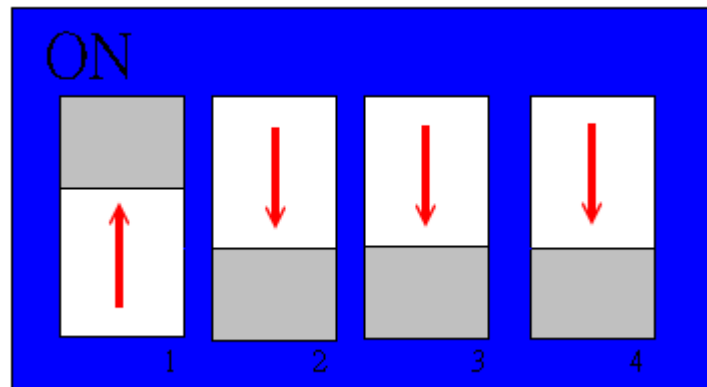

Figure 3.2 DIP switch setting

- ◆ NV-520G function config over DIP Switch. (shown in [Table 3-2](#))

Configuration Table 3-2

DIP Switch on rear panel				Config Mode	Description
PIN1	PIN2	PIN3	PIN4		
OFF	OFF	OFF	OFF	Sy-Auto I_8/2 (SNRM 8/8)	Symmetric Auto, Max. Interleave=8, Min.Inp=2, SNRM=8 (Default)
OFF	ON	OFF	OFF	NSy-Auto I_8/2 (SNRM 8/8)	non symmetric Auto, Max. Interleave=8, Min.Inp=2, SNRM=8
OFF	OFF	ON	OFF	Sy-Auto I_8/2 (SNRM 6/6)	Symmetric Auto, Max. Interleave=8, Min.Inp=2, SNRM=6
OFF	ON	ON	OFF	NSy-Auto I_8/2 (SNRM 6/6)	Non symmetric Auto, Max. Interleave=8, Min.Inp=2, SNRM=6
OFF	OFF	OFF	ON	Sy-Auto G.INP_17/2/41 (SNRM 12/12)	Symmetric Auto, enable G.INP, enable re-transmission, SNRM=12
OFF	ON	OFF	ON	NSy-Auto G.INP_17/2/41 (SNRM 12/12)	non symmetric Auto, enable G.INP, enable re-transmission, SNRM=12
OFF	OFF	ON	ON	Sy-30a-D2.2M G.INP_17/2/41 (Rate 20/20) (SNRM 24/24)	Symmetric 30a, disable 0~2.2MHz, enable G.INP, enable re-transmission, Max.Line rate=20Mbps, SNRM=24
OFF	ON	ON	ON	Annex-A-17a-eu32_I-8/2 (SNRM 6/6)	17A Annex a Eu32, Max. Interleave=8, Min. Inp=2, SNRM=6
ON	NA	NA	NA	CPE Mode	<u>Switching to Slave mode</u>

Note:

1. The DIP switch default values are OFF.
2. Please power off NV-520G, before making any transmission mode configuration.

TIP (Reference Only):

Interleave delay function is used in digital data transmission technology to protect the transmission against noise issue and data errors.

If during transit more than a certain amount of data has been lost, then the data cannot be correctly decoded. Short bursts of noise on the line can cause these data packets to become corrupt and NV-520G has to re-request data which in turn can slow down the overall rate at which data is transmitted.

Interleaving is a method of taking data packets, chopping them up into smaller bits and then rearranging them so that Once contiguous data is now spaced further apart into a non continuous stream. Data packets are re-assembled by NV-520G.

The diagram below is an example of how interleaved traffic is transmitted.

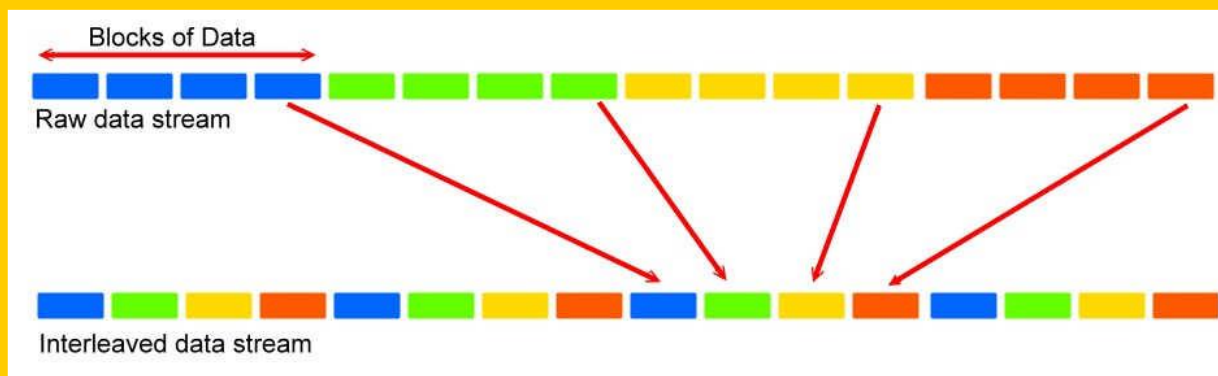

If your line is particularly susceptible to bursts of noise, then interleaving should improve VDSL2 Line experience simply because if you lose a whole batch of data then this could cause VDSL2 Line port to lose sync with the exchange.

Using Interleaving, NV-520G is able to re-assemble the data or if necessary that re-request the part of the data that it is

unable to recover. By increasing the interleave depth of each port that is susceptible to noise, this will improve error performance and stability of marginal lines.

INP (Impulse Noise Protection): Impulse noise in multicarrier communication systems behaves effectively as a modulating signal that controls the first moment of the background Gaussian noise. The composite noise, which is the aggregate of the Gaussian noise and impulse noise, has a probability density function that is conditionally Gaussian with non-zero average, hence referred to as biased-Gaussian. The BER-equivalent power of the composite noise source is defined as the power of a pure Gaussian noise source that yields the same bit-error rate (BER). The BER-equivalent noise for a biased-Gaussian noise is simply the amplified version of the underlying Gaussian noise source. The amplification factor is derived from the characteristics of impulse interference. Any bit-loading algorithm designed for Gaussian noise sources is also applicable to biased-Gaussian noise sources provided that the BER-equivalent SNR is used in place of the measured SNR.

G.INP / G998.4

G.998.4 is a newer alternative to FEC (Forward Error Correction) and interleaving to providing a lower overhead (FEC loses about 12% whereas G.INP only corrects errors when they actually occur) so there is little overhead. G.998.4 was formerly known as G.INP and may also be referred to as Impulse Noise Protection or Physical Retransmission (PHY-R).

G998.4 operates at the physical layer. The transmitting modem keeps a copy of transmitted data in a retransmission buffer. If the receiver detects corruption (by way of a checksum) retransmission is request. If the transmitter responds in time, the data is repaired. The round-tip time of retransmission should be <4ms. If the transmitter doesn't retransmit in time, the corrupt data is forwarded for higher level protocols to sort out.

3.2 Front Indicators

NV-520G supports **Eight** LED indicators. The following Table shows the description. (Table 3-3)

Table 3-3 LED Indicators Description and Operation

LED	Color	Status	Descriptions
PWR (Power LED)	Green	On (Steady)	Lights to indicate that NV-520G is under power good
		Off	The device is not ready or has malfunctioned.
ETHERNET 1-4 (Ethernet LED)	Green	On (Steady)	The device has a good Ethernet connection.
		Blinking	The device is sending or receiving data.
		Off	LAN port is not connected.
CO (CO LED)	Green	On (Steady)	Indicates NV-520G operating in CO(Master) mode.
CPE (CPE LED)	Green	On (Steady)	Indicates NV-520G operating in CPE(Slave) mode.
LINK (VDSL LED)	Green	On (Steady)	The Internet or network connection is up.
		Blinking slowly	Indicates NV-520G on standby
		Blinking fastly	1. NV-520G detected a CPE device and ready to connect. 2. The device is sending or receiving data.
		Off	The Internet or network connection is down or has malfunctioned.

Note:

Two of NV-520G connection may take within 3 minutes is normal, due to NV-520G to establish a link mechanism is auto-negotiation, with detects and calculate CO and CPE both PBO and PSD level as well as noise leveland other argument etc. for getting a better connection.

3.3 Rear Panel

The following figure shows the rear panel. (Figure 3.3)

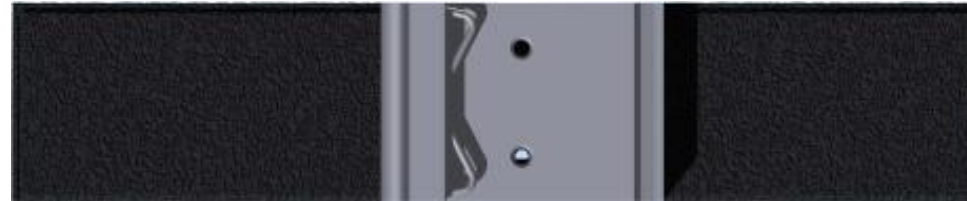

Figure 3.3 Rear Panel

Note:

Please refer to section 2.5 to install DIN RAIL.

3.4 Side Panel

The following figure shows the side. (Figure 3.4)

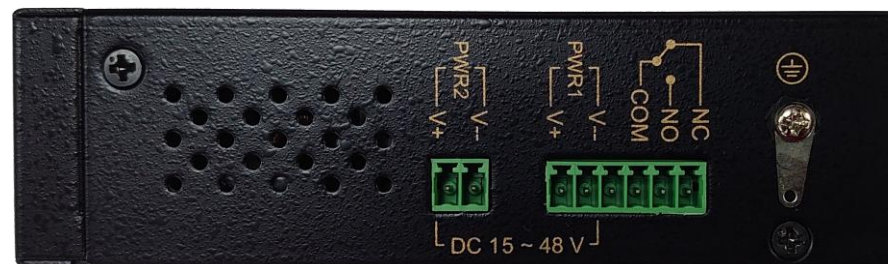
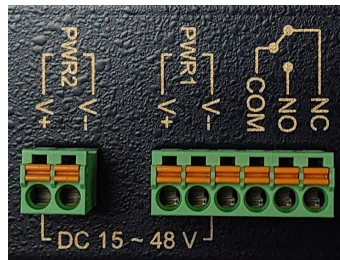

Figure 3.4 Rear connectors

The following descriptions introduce Dual power and Relay Contact.

Wiring the dual Power Inputs

The NV-520G supports two sets of power inputs, power 1 and power 2, which are located on NV-520G's side panel. Power 1 is the bottom two contacts on the upper 6-contact terminal block and power 2 is the top two contacts on the lower 2-contact terminal block.



STEP 1: Insert the negative/positive DC wires into the V-/V+ terminals, respectively.

STEP 2: Place the DC wires into terminal block connector: Push the orange switch of the terminal block with a small flat-blade screwdriver, then the DC wires insert the orange button below of the circle hole and release the small flat-blade screwdriver.

STEP 3: Insert the plastic terminal block connector prongs into the terminal block receptor, which is located on the NV-520G's side panel.

Attention:

1. Please note that the negative DC wire must connect into the V- terminal, positive DC wire must connect V+ terminal. If contrary to the location of the wiring, NV-520G will enable Reverse Polarity Protection function automatically. DC power will not be able to go directly through the machine.
2. Please note that if the DC power current exceeds 3A, NV-520G will enable Overload Current Protection function automatically. DC power will not be able to go directly through the machine.

Safety Caution!

1. Be sure to disconnect the power when installing (uninstalling) the terminal block and power cables.
2. Please note that NV-520G accepts 15~48VDC dual power input (Redundant Power). Do not exceed DC 48V.
3. Be sure to disconnect the power before installing and/or wiring NV-520G.
4. Please calculate the maximum possible current in each power and common wire. Observe all electrical codes dictating the maximum current allowable for each wire size. If the current goes above the maximum ratings, the wiring could overheat, causing serious damage to your equipment.

Power Input Status

The following Table shows the examples of the power input status. (Table 3-4)

Table 3-4

		Example 1				Example 2				Example 3			
Power Item	Default Polarity	Power Input1	Output State1	Power Input2	Output State2	Power Input1	Output State1	Power Input2	Output State2	Power Input1	Output State1	Power Input2	Output State2
Power 1	-	15V-	OFF	15V-	ON	15V+	Protection	15V+	Protection	48V-	ON	No Power	OFF
	+	15V+		15V+		15V-		15V-		48V+			
Power 2	-	24V-	ON	No Power	OFF	24V-	ON	No Power	OFF	48V-	ON	48V-	ON
	+	24V+				24V+				48V+		48V+	

		Example 4				Example 5				Example 6			
Power Item	Default Polarity	Power Input1	Output State1	Power Input2	Output State2	Power Input1	Output State1	Power Input2	Output State2	Power Input1	Output State1	Power Input2	Output State2
Power 1	-	15V-	Malfunction	15V-	Malfunction	15V-	ON	15V-	Malfunction	48V-	ON	No Power	OFF
	+	15V+		15V+		15V+		48V+					
Power 2	-	60V-	Malfunction	No Power	Malfunction	No Power	OFF	60V-	Malfunction	48V+	Protection	48V+	Protection
	+	60V+						60V+		48V-		48V-	

Notes:

1. State 1 always happens before state 2.
2. Protection means enable Reverse Polarity Protection function.
3. Please note that if user uses different DC voltage, higher voltage will feed to NV-520G first.
4. Please note that the warranty is void if DC 48V power input is exceeded.

Wiring the Relay Contact

NV-520G has a set of relay outputs. The relay contact uses of the terminal block's contacts located on NV-520G's side panel. Refer to the following table shows how to connect the wires to the terminal block connector. In this section, we illustrate the meaning of the two contacts used to connect the relay contact.

Fault Tip:

The relay contacts of the 3-pins terminal block connector are used to detect a power failure warning event. Wires connected to Warning Device over normal open contact (COM & NO) for detecting power system. If a power failure does not occur, the fault circuit remains open. The current carrying capacity of relay contact is 1 A @ 24 VDC/ @ 125 VAC. This function triggered by built-in relay.

The following Table shows the Relay circuit and power status. (Table 3-5)

Table 3-5 Relay Circuit Status and Power good/failure Status.

	Power good	COM & NC	Open Circuit
		COM & NO	Short Circuit
	Power failure	COM & NC	Short Circuit
		COM & NO	Open Circuit

Grounding the NV-520G

NV-520G is designed to enhance EMS performance by grounding. NV-520G comes with metal DIN-Rail brackets for grounding the switches. For optimal EMS performance, connection of the right of the NV-520G side panel ground lugs to the grounding point.

Note:

Please connect the ground lug to the earth to prevent electric shock, when the user touches.

Before user installed power and device, please read and follow these essentials:

- ◆ Use separate paths to route wiring for power and devices. If power wiring and device wiring paths must cross, make sure the wires are perpendicular at the intersection point.

Note:

Do not run signal or communications wiring and power wiring through the same wire conduit. To avoid interference, wires with different signal characteristics should be routed separately.

- ◆ You can use the type of signal transmitted through a wire to determine which wires should be kept separate. The rule of thumb is that wiring sharing similar electrical characteristics can be bundled together.
- ◆ You should separate input wiring from output wiring.
- ◆ We recommend that you mark all equipment in the wiring system.



Appendix A: Cable Requirements

Ethernet Cable

A CAT 5~7 UTP (unshielded twisted pair) cable is typically used to connect the Ethernet device to the Modem. A: 10/100TX cable often consists of four pairs of wires, two of which are used for transmission. The connector at the end of the 10/100TX cable is referred to as a RJ-45 connector and it consists of eight pins. The Ethernet standard uses pins 1, 2, 3 and 6 for data transmission purposes. (Table A-1 10/100TX)

B: 1000TX cable often consists of four pairs of wires, all of which are used for transmission. The connector at the end of the 1000TX cable is referred to as a RJ-45 connector and it consists of eight pins. The Ethernet standard uses pins 1, 2, 3, 4, 5 and 6 for data transmission purposes. (Table A-1 1000TX)

Table A-1 RJ-45 Ethernet Connector Pin Assignments

PIN #	10/100TX		1000TX	
	Signal	Media Dependant interface	Signal	Media Dependant interface-cross
1	TX+	Transmit Data+	BI_DA+	Bi-directional pair A+
2	TX-	Transmit Data-	BI_DA-	Bi-directional pair A-
3	RX+	Receive Data+	BI_DB+	Bi-directional pair B+
4	NC	Unused	BI_DC+	Bi-directional pair C+
5	NC	Unused-	BI_DC-	Bi-directional pair C-
6	RX-	Receive Data-	BI_DB-	Bi-directional pair B-
7	NC	Unused	BI_DD+	Bi-directional pair D+
8	NC	Unused	BI_DD-	Bi-directional pair D-

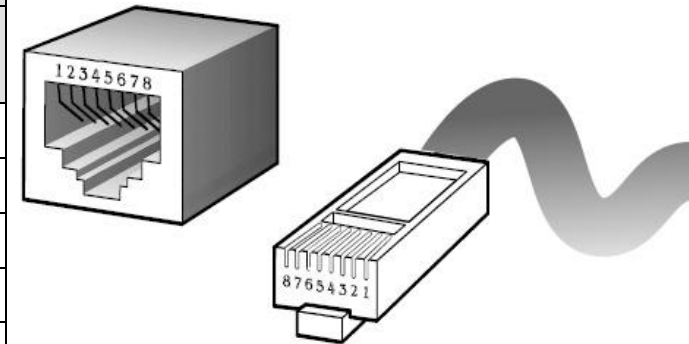

Figure A-1 Standard RJ-45 receptacle / connector

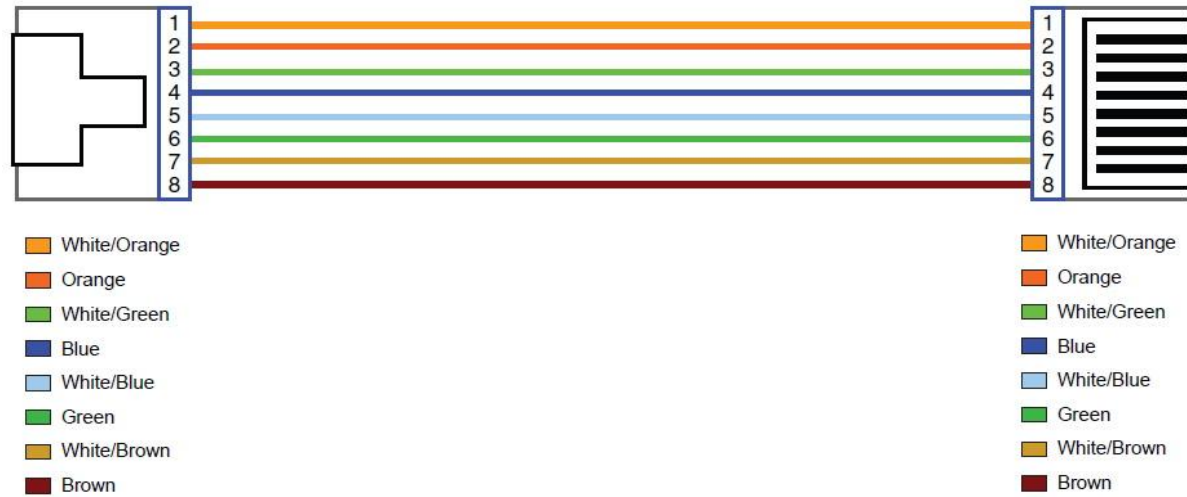

Figure A-2 Pin Assignments and Wiring for an RJ-45 Straight-Through Cable



Figure A-3 Pin Assignments and Wiring for an RJ-45 Crossover Cable

Appendix B: Product Specification

Key Features & Benefits

- Supports high bandwidth up to 160Mbps symmetric over Line ports
- Supports 4 x 10/100/1000M Ethernet ports
- Supports RJ11/Terminal block combo line port
- Supports long reach mode up to 3 km with 24-gauge phone wire
- Supports Interleave depth & G998.4 G.INP
- Supports auto speed and 8 profiles mode selectable by DIP switch
- DIP switch with Master and Slave mode selectable
- Supports Jumbo frame up to 2k bytes
- Supports VLAN Tag passthrough
- Supports Surge protection
- Supports power redundant and wide range dual power input (DC15V ~ 48V)
- Supports Overload Current Protection
- Supports wide range operating temperature (-20°C ~ 70°C)
- Supports Reverse Polarity Protection
- Supports alarm contact (relay output - 1 A @ 24 VDC)
- Supports DIN-Rail mount installation
- Metal case design and compliant with IP30 standard

Product Specification

Standard:	IEEE802.3/802.3u/802.3ab Ethernet standard G993.2 VDSL2 standard
Physical Interface:	4 * RJ-45 10/100/1000Mbps Ethernet port 1 * RJ-11/Terminal Block connector for VDSL2 line port 1 * DIP Switch 1 * removable 6-contact terminal blocks for power1 and alarm contact 1 * removable 2-contact terminal blocks for power2
LED Indicators:	1 * Power LED 4 * Link/Active Status for Ethernet port 1 * Link/Speed for VDSL2 port 1 * CO Mode indicator LED 1 * CPE Mode Indicator LED
VDSL2 Line Code:	Discrete multitone (DMT) modulation
VDSL 2Transmission Mode:	Packet Transfer Mode (PTM)
Maximum Power Consumption:	6 W
Power Supply:	Redundant dual DC input power 15~48V (Removable Terminal Block)
EMC:	EMI Compliant: FCC class A EMS Compliant: CE mark
Operating Temperature:	-20°C ~ 70°C (-4°F ~ 158°F)

	Fanless, free air cooling
Storage Temperature:	-40°C ~ 70°C (-40°F ~158°F)
Humidity:	5% to 95% (non-condensing)
Weight:	0.63 kg
Dimensions:	171 x 121 x 35 mm (6.7" x 4.76" x 1.37")

Appendix C: Troubleshooting

Diagnosing NV-520G's Indicators

NV-520G can be easily monitored through its comprehensive panel indicators. These indicators assist the network manager in identifying problems the hub may encounter. This section describes common problems you may encounter and possible solutions.

1. Symptom:	POWER indicator does not light up (green) after power on.
Cause:	Defective External power supply
Solution:	Check the power plug by plugging in another that is functioning properly. Check the power cord with another device. Check the terminal block and make sure to fasten the power cord. If these measures fail to resolve the problem, have the unit power supply replaced by a qualified distributor.
Note:	Please refer to the power status table to check power input status. Section 3.4

2. Symptom:	Link indicator does not light up (green) after making a connection.
Cause:	Network interface (ex. a network adapter card on the attached device), network cable, or switch port is defective.
Solution:	<ol style="list-style-type: none"> 2.1 Power off and re-power on NV-520G. 2.2 Verify that the switch and attached device are power on. 2.3 Be sure the cable is plugged into both the switch and corresponding device. 2.4 Verify that the proper cable type is used, and its length does not exceed specified limits. 2.5 Check NV-520G on the attached device and cable connections for possible defects. 2.6 Make sure that the phone wire must be connecting NV-520G first, when powered on. 2.7 Replace the defective NV-520G or cable if necessary.

3. Symptom:	VDSL Link cannot be established.
Cause:	VDSL setting failure or phone cable length is over the specification limit.
Solution:	<p>3.1 Please make sure that the phone wire must be connected between NV-520G (CO) and NV-520G (CPE) when both are power on. NV-520G (CO) will do auto speed function depending on phone wire length and quality, therefore if NV-520G (CO) can't detect NV-520G (CPE) over phone wire while both power on, this will cause the link to fail.</p> <p>3.2 Please check phone wire, we recommend using 24-26 gauge with twisted pair and without rust.</p> <p>3.3 Please check the correct Dip Switch setting.</p> <p>3.4 Please reinsert power when changing cable length or link time over 3 minutes.</p>
Note:	Phone wire must meet CAT 3 standard or above and without clustering , otherwise will cause more cross talk issues to reduce DSL power driver.
4. Problem:	What is VDSL2?
Answer:	<p>Very-high-speed digital subscriber line 2 (VDSL2) is an access technology that exploits the existing infrastructure of copper wires that were originally deployed for traditional telephone service. It can be deployed from central offices, from fiber-optic connected cabinets located near the customer premises, or within buildings. It was defined in standard ITU-T G.993.2 finalized in 2005.</p> <p>VDSL2 was the newest and most advanced standard of digital subscriber line (DSL) broadband wireline communications. Designed to support the wide deployment of triple play services such as voice, video, data, High-Definition Television (HDTV) and interactive gaming, VDSL2 was intended to enable operators and carriers to gradually, flexibly, and cost-efficiently upgrade existing xDSL infrastructure.</p>

The protocol was standardized in the International Telecommunication Union telecommunications sector (ITU-T) as Recommendation G.993.2. It was announced as finalized on 27 May 2005,[1] and first published on 17 February 2006. Several corrections and amendments were published in 2007 through 2011.

VDSL2 is an enhancement to very-high-bitrate digital subscriber line (VDSL), Recommendation G.993.1. It permits the transmission of asymmetric and symmetric aggregate data rates up to 200 Mbit/s downstream and upstream on twisted pairs using a bandwidth up to 30 MHz.

VDSL2 deteriorates quickly from a theoretical maximum of 250 Mbit/s at source to 100 Mbit/s at 0.5 km (1,600 ft) and 50 Mbit/s at 1 km (3,300 ft), but degrades at a much slower rate from there, and still outperforms VDSL. Starting from 1.6 km (1 mi) its performance is equal to ADSL2+.

ADSL-like long reach performance is one of the key advantages of VDSL2. LR-VDSL2 enabled systems are capable of supporting speeds of around 1–4 Mbit/s (downstream) over distances of 4–5 km (2.5–3 miles), gradually increasing the bit rate up to symmetric 100 Mbit/s as loop-length shortens. This means that VDSL2-based systems, unlike VDSL1 systems, are not limited to short local loops or MTU/MDUs only but can also be used for medium range applications.

5. Problem:	What is SNR(Signal-to-Noise)
Answer:	Signal-to-noise ratio (often abbreviated SNR or S/N) is a measure used in science and engineering that compares the level of a desired signal to the level of background noise. It is defined as the ratio of signal power to noise power. A ratio higher than 1:1 indicates more signal than noise. While SNR

is commonly quoted for electrical signals, it can be applied to any form of signal (such as isotope levels in an ice core or biochemical signaling between cells). The ratio is usually measured decibels(dB)

The signal-to-noise ratio, the bandwidth, and the channel capacity of a communication channel are connected by the Shannon–Hartley theorem.

In digital communications, the SNR will probably cause a reduction in data speed because of frequent errors that require the source (transmitting) computer or terminal to resend some packets of data. SNR measures the quality of a transmission channel over a network channel. The greater the ratio, the easier it is to identify and subsequently isolate and eliminate the source of noise.

System Diagnostics

Power and Cooling Problems

If the POWER indicator does not turn on when the power cord is plugged in, you may have a problem with the power outlet, power cord, or internal power supply as explained in the previous section. However, if the unit power is off after running for a while, check for loose power connections, power losses or surges at the power outlet. If you still cannot isolate the problem, then the internal power supply may be defective. In this case, please contact your local dealer.

Installation

Verify that all system components have been properly installed. If one or more components appear to be malfunctioning (e.g. the power cord or network cabling), test them in an alternate environment where you are sure that all the other components are functioning properly.

Transmission Mode

The default method of selecting the transmission mode for RJ-45 ports is 10/100/1000 Mbps ETHERNET, for RJ-11 ports are auto-negotiation VDSL. Therefore, if the Link signal is disrupted (e.g. by unplugging the network cable and plugging it back in again, or by resetting the power), the port will try to reestablish communications with the attached device via auto-negotiation. If auto-negotiation fails, then communications are set to half duplex by default. Based on this type of industry-standard connection policy, if you are using a full-duplex device that does not support auto-negotiation, communications can be easily lost (i.e. reset to the wrong mode) whenever the attached device is reset or experiences a power fluctuation. The best way to resolve this problem is to upgrade these devices to a version that supports Ethernet and VDSL.

Physical Configuration

If problems occur after altering the network configuration, restore the original connections, and try to track the problem down by implementing the new changes, one step at a time. Ensure that cable distances and other physical aspects of the installation do not exceed recommendations.

System Integrity

As a last resort verify the switch integrity with a power-on reset. Turn the power to the switch off and then on several times. If the problem still persists and you have completed all the preceding diagnoses, then contact your dealer.

Appendix D: IP-30 protection of metal case

The term “protection class” generally indicates the type of protection of a device or the internal workings of a device against direct contact and against the infiltration of foreign bodies, such as objects, dust or water.

The resistance to stress arising from prevailing working conditions is defined using international protection (IP) classes. These protection classes are, in turn, indicated in IP standards (DIN EN 60529), whereby a combination of two digits specifies the level of protection. The first digit indicates the level of resistance to foreign bodies and dust, the second digits the level of resistance to water infiltration. A higher value of the relevant digit (first digit 0 – 6, second digit 0 - 8) indicates a higher level of protection.

The table on the following offers clarity and an overview of the IP rules:

Table D-1 First Digit: Protection grades for contact and foreign matter protection.

Digit	Designation	Explanation
0	No protection	No special protection to prevent infiltration by solid objects.
1	Protection against large foreign matter	Protection against solid objects greater than 50 millimeters in diameter.
2	Protection against mediumsized Foreign matter	Protection against solid objects greater than 12.5 millimeters in diameter.
3	Protection against small foreign matter	Protection against solid objects greater than 2.5 millimeters in diameter.
4	Protection against circular foreign matter	Protection against solid objects greater than 1 millimeter in diameter.
5	Dust protected	Complete protection against dust is not necessary, but infiltration must be prevented to a sufficiently high degree to ensure that the functioning and safety of the device are not impaired.
6	Dustproof	Complete protection against dust infiltration

Table D-2 Second Digit: Protection grades for water protection.

Digit	Designation	Explanation
0	No protection	No special protection to prevent water infiltration.
1	Protection against vertically dripping water	Water dripping vertically on to the device may not have any harmful effect.
2	Protection against water dripping at an angle	Water dripping vertically onto a device tilted to an angle of up to 15° from the vertical may not have any harmful effect.
3	Protection against spray water	Protection against water sprayed at any angle up to 60° from the vertical on to the device.
4	Protection against splash water	Water splashing against the device from any direction may not have any harmful effect.
5	Protection against water jets	A jet of water aimed at the housing from any direction may not have any harmful effect.
6	Protection against strong water jets	A strong water jet aimed at the device from any direction may not have any harmful effect.
7	Protection against temporary immersion	When the device is immersed in water up to 1 meter from the lower edge of the device, water may not enter the device in any sufficient quantity to cause damage.
8	Protection against continuous immersion	The device is suitable for continuous immersion in water. The conditions must be individually agreed between the manufacturers and the user but must, at least, exceed the specification of digit 7.

Appendix E: Compliance Information

FCC Radio Frequency Interference Statement

This equipment has been tested and found to comply with the limits for a computing device, pursuant to Part 15 of FCC rules. These limits are designed to provide reasonable protection against harmful interference when the equipment is operated in a commercial environment. This equipment generates uses and can radiate radio frequency energy and, if not installed and used in accordance with the instructions, may cause harmful interference to radio communications. However, there is no guarantee that interference will not occur in a particular installation. If this equipment does cause harmful interference to the radio or television reception, which can be determined by turning the equipment off and on, the user is encouraged to try to correct the interference by one or more of the following measures:

1. Reorient or relocate the receiving antenna.
2. Increase the separation between the equipment and receiver.
3. The equipment and the receiver should be connected to outlets on separate circuits.
4. Consult the dealer or an experienced radio/television technician for help.

Changes or modifications not expressly approved by the party responsible for compliance could prevent the user's authority to operate the equipment.

If this telephone equipment causes harm to the telephone network, the telephone company will notify you in advance that temporary discontinuance of service may be required. But if advance notice isn't practical, the telephone company will notify the customer as soon as possible. Also, you will be advised of the right to file a complaint with the FCC if you believe it is necessary.

The telephone company may make changes to its facilities, equipment, operations or procedures that could affect the

proper functioning of your equipment. If they do, you will be notified in advance in order for you to make necessary modifications to maintain uninterrupted service.

This equipment may not be used on the coin service provided by the telephone company. Connection to party lines is subject to state tariffs.

FCC Warning



This equipment has been tested to comply with the limits for a Class A digital device, pursuant to Part 15 of the FCC Rules. These limits are designed to provide reasonable protection against harmful interference when the equipment is operated in a commercial environment. This equipment can generate, use, and radiate radio frequency energy and, if not installed and used in accordance with the instruction manual, may cause harmful interference to radio communications. Operation of this equipment in a residential area is likely to cause harmful interference in which case the user will be required to correct the interference at owner's expense.

CE Mark Warning



This is a class A product. In a domestic environment, this product may cause radio interference in which case the user may be required to take adequate measures.

RoHS Mark Warning



RoHS stands for Restriction of Hazardous Substances and impacts the entire electronics industry and many electrical products as well. The original RoHS, also known as Directive 2002/95/EC, originated in the European Union in 2002 and restricts the use of six hazardous materials found in electrical and electronic products. All applicable products in the EU market from July 1, 2006, must pass RoHS compliance. Directive 2011/65/EU was published in 2011 by the EU, which is known as RoHS-Recast or RoHS 2. RoHS 2 includes a **CE-marking directive**, with RoHS compliance now being required for CE marking of products. RoHS 2 also added Categories 8 and 9 and has additional compliance recordkeeping requirements. Directive 2015/863 was published in 2015 by the EU, which is known as RoHS 3. RoHS 3 adds four additional restricted substances (phthalates) to the list of six.

WEEE Warning



To avoid the potential effects on the environment and human health as a result of the presence of hazardous substances in electrical and electronic equipment, end users of electrical and electronic equipment should understand the meaning of the cross-out wheeled bin symbol. Do not dispose of WEEE in unsorted municipal waste and has to collect such WEEE separately.



ErP Power Usage

This device is an Energy Related Product (ErP) with High Network Availability (HiNA). If it is not needed during certain periods of time, it can be unplugged to save energy.

Network Standby: 3.8 watts.

Warranty

The original owner that the product delivered in this package will be free from defects in material and workmanship for one-year parts after purchase.

There will be a minimal charge to replace consumable components, such as fuses, power transformers, and mechanical cooling devices. The warranty will not apply to any products which have been subjected to any misuse, neglect or accidental damage, or which contain defects which are in any way attributable to improper installation or to alteration or repairs made or performed by any person not under the control of the original owner.

The above warranty is in lieu of any other warranty, whether express, implied, or statutory, including but not limited to any warranty of merchantability, fitness for a particular purpose or any warranty arising out of any proposal, specification or sample. We shall not be liable for incidental or consequential damages. We neither assume nor authorize any person to assume for it any other liability.



WARNING:

DO NOT TEAR OFF OR REMOVE THE WARRANTY STICKER AS SHOWN, OR THE WARRANTY IS VOID.

Chinese SJ/T 11364-2024

部件名称	有毒有害物质或元素									
	铅(Pb)	汞(Hg)	镉(Cd)	六价铬 [Cr(VI)]	多溴联苯 (PBB)	多溴二苯 醚(PBDE)	邻苯二甲 酸二(2- 乙基己 基)酯 (DEHP)	邻苯二甲 酸丁酯苯 甲酯 (BBP)	邻苯二甲 酸二丁酯 (DBP)	邻苯二甲 酸二异丁 酯 (DIBP)
结构壳体	○	○	○	○	○	○	○	○	○	○
电路组	○	○	○	○	○	○	○	○	○	○
电源供应器	○	○	○	○	○	○	○	○	○	○
线材	○	○	○	○	○	○	○	○	○	○
包装及配件	○	○	○	○	○	○	○	○	○	○
○：表示该有毒物质在该部件所有均质材料中的含量均在 GB/T 39560 标准规定的限量要求以下。 ×：表示该有毒物质至少在该部件的某依均质材料中的含量超出 GB/T 39560 标准规定的限量要求。										

上述规范仅适用于中国法律